

**14TH CONCESSION WEST DRAIN**

**Bridge Replacement for Santo Farms Seed Company**

**Geographic Township of Colchester North**



**TOWN OF ESSEX**  
**33 Talbot Street South**  
**ESSEX, Ontario N8M 1A8**  
**519-776-7336**

***Rood Engineering Inc.***

***Consulting Engineers***

***9 Nelson Street***

***Leamington, Ontario N8H 1G6***

***519-322-1621***

Project REI2025D001

2026-05-08



May 8th, 2026

Mayor and Municipal Council  
Corporation of the Town of Essex  
33 Talbot Street South  
Essex, Ontario  
N8M 1A8

**14TH CONCESSION WEST DRAIN**  
**Bridge Replacement for Santo Farms Seed Company (600-05700)**  
**Geographic Township of Colchester North**  
**Town of Essex, County of Essex**  
***Our Project REI2025D001***

**I. INTRODUCTION**

In accordance with the letter instructions received via email from the Town of Essex of June 16th, 2025, we have prepared the following Engineer's Report that provides for the construction of a replacement access bridge in the 14th Concession West Drain. This proposed bridge replacement is intended to provide a safer access across the drain for the agricultural lands owned by Santo Farms Seed Company (600-05700), in South Part of Lot 2, Concession 14, in the former Geographic Township of Colchester North. The 14th Concession West Drain is an open drain with a number of access bridges constructed pursuant to the Drainage Act. A plan showing the alignment of the 14th Concession West Drain, the general location of the subject access bridge and the details of the new replacement access bridge is included herein as part of this report.

Our appointment and the works related to the construction of the replacement access bridge in the 14th Concession West Drain, proposed under this report, is in accordance with Section 78 of the "Drainage Act, R.S.O. 1990, Chapter D.17 as amended 2021". We have performed all of the necessary survey, investigations, etc. for the proposed improvements to the subject replacement access bridge in the 14th Concession West Drain, and we report thereon as follows.

**II. BACKGROUND**

The 14th Concession West Drain begins upstream in Lot 10, Concession 14 and continues westerly along the north side of the 14th Concession Road where it then heads southerly for a short distance on the east side of Walker Road (County Road 11) where it outlets into the Shuell Creek Drain in the Town of Amherstburg.

From our review of the Town of Essex's drainage files, we have determined that the 14th Concession West Drain was last repaired and improved under an Engineer's Report prepared by

C.G.R. Armstrong, P.Eng. dated May 11th, 1962, adopted by By-Law No. 1602. This report provided for general repairs and improvements to the entire length of the drain and included plans, profile and cross-section of the drain.

We have utilized the 1962 Armstrong report to establish the necessary size parameters and profile grades for the drain as well as the details to be used in establishing the replacement of the subject access bridge. Additionally, the Schedule of Assessment provided in said report was used to establish the upstream watershed area for confirming flows used in the design of the replacement access bridge as well as establishing the assessment schedule for the work as per the provisions of that report.

### **III. PRELIMINARY EXAMINATION AND ON-SITE MEETING**

After reviewing all of the relevant drainage information and documentation provided by the Town, we arranged with Town staff to hold an on-site meeting for August 19th, 2025. The following landowners were in attendance at said meeting:

- Keith Martin                      13082 Old Malden Road
- Richard Drouillard              9836 County Road 11
- Sharleen Robinet                14017 County Road 11
- Patrick Robinet                 14017 County Road 11
- Josh Meloche                    14031 County Road 11
- Richard Deslippe                14029 County Road 11
- Doug Garrod                     14027 County Road 11
- Dan Reaume                     14405 14th Concession Road
- Chad Santo                        7495 11th Concession Road
- Rosemary Meloche              15415 County Road 8
- John Bressan                     14033 County Road 11
- David Santo                      14689 14th Concession Road
- Joseph Drouillard                13073 13th Concession Road

In addition to the above noted landowners, the following stakeholders were also in attendance:

- Lindsay Dean                    Town of Essex - Drainage Superintendent
- Tanya Tuzlova                  Town of Essex - Operations/Drainage Clerk
- Shawn Mulder                  County of Essex - Supervisor of Roads Maintenance
- David Montigny                 Rood Engineering Inc.

The Town of Essex Drainage Superintendent completed introductions. David Montigny explained that Rood Engineering Inc. has been appointed by Municipal Council as the engineering firm for this project. The purpose of the on-site meeting was also explained.

The Town of Essex received a request by Santo Farms Seed Company (600-05700) for repairs and/or improvements to the existing access bridge currently providing access to their lands

across the 14th Concession West Drain. Specifically, the landowner requested improvements to extend the existing bridge and increase the top width in order to facilitate access for large agricultural equipment.

It was observed that the existing access bridge is a concrete span bridge with wingwalls which provides a relatively narrow top width and is visibly deteriorated. It was explained that the Engineer's assessment of the condition of the existing structure and its expected serviceable lifespan would ultimately determine if it would be extended or completely replaced.

If the existing access bridge is found to be in good condition, it is expected that both sides of the structure would be extended by connecting manufactured concrete slabs to the existing wingwalls. However, if the existing access bridge is found to be in poor condition and in need of being replaced, the existing structure would be completely removed, and a new replacement bridge would be constructed in the drain. It is expected that a corrugated steel pipe would be acceptable for the replacement, similar to other access bridges along the drain. It was further discussed that sloped quarried limestone on filter cloth was expected to be the most economical end treatment, but other alternatives such as precast concrete blocks would be reviewed.

Ultimately, the Engineer would contact the landowner to confirm the details of the proposed bridge extension or replacement prior to proceeding. Regardless of the recommended design, the works will be subject to the approval and mitigation measures of the Department of Fisheries and Oceans (DFO), the Ministry of Natural Resources (MNR), the Ministry of Environment, Conservation and Parks (MECP), and the Essex Region Conservation Authority (ERCA).

The requesting landowner was advised that the minimum standard top width for an access bridge is 6.10 metres (20.0 ft). Any cost for additional top width beyond the standard shall be 100% assessable to the abutting landowner for both the initial construction as well as future maintenance. If the existing access bridge is extended, it is expected that the cost of the construction, including the cost for the preparation of the Engineer's Report would be 100% assessable to the abutting landowner. However, if the existing access bridge is replaced, the cost of the new replacement access bridge construction, including the cost for the preparation of the Engineer's Report would be shared by the abutting landowner and upstream lands and roads within the watershed.

Future maintenance processes and grant eligibility were generally reviewed with the landowners in attendance. It was explained that the Engineer's Report will set out the cost sharing for future maintenance work on the access bridge.

The general procedure through the Drainage Act and expected timelines were discussed. It was confirmed that only affected owners will have the opportunity to review the Engineer's Report and will be notified of the various meetings as required by the Drainage Act.

#### **IV. FIELD SURVEY AND INVESTIGATIONS**

Following the on-site meeting we arranged for our survey crew to attend the site and perform a topographic survey, including taking the necessary levels and details of the 14<sup>th</sup> Concession West Drain to establish the design parameters for the replacement access bridge.

A benchmark was looped from previous work carried out on the drain and was utilized in establishing a site benchmark near the location of the subject access bridge. We also surveyed the drain both upstream and downstream of the proposed replacement access bridge in order to establish a design grade profile for the installation of the replacement bridge. We also took cross-sections of the 14th Concession West Drain at the general location of the existing access bridge, as necessary for us to complete our design calculations, estimates and specifications.

Prior to our appointment to this project, the Town of Essex submitted notification to the Essex Region Conservation Authority (ERCA) regarding their comments and concerns related to the replacement access bridge over the 14th Concession West Drain. Initial comments from ERCA were received and confirmed that the subject access bridge is located within a regulated area administered by ERCA. Accordingly, a permit or approval will be required by ERCA for the construction of the new replacement access bridge. Subsequent to their initial comments and upon their request, preliminary designs were submitted to ERCA for review. The response provided by ERCA confirmed that they did not have major concerns and were generally supportive of the proposal for the replacement access bridge.

As of March 30th, 2026, the Endangered Species Act (ESA), 2007 has been replaced by the Species Conservation Act (SCA), 2025 administered by the Ministry of Environment, Conservation and Parks (MECP). Under the now repealed ESA, exemption provisions of Section 23.9 of Ontario Regulation 242/08 allowed the Town to carry out repairs, maintenance and improvements within existing Municipal Drains. These works were exempt from Sections 9 and 10 of the ESA provided that the rules in the regulations were followed. If eligible, the exemption provisions of the legislation allowed the Town to give notice to the Ministry by registering their drainage activities through an online registry system. Under the new SCA, drainage works are no longer excepted, and the Town needs to register drainage activities, that will, or are likely to, impact species listed on the Protected Species in Ontario List regulation or their habitat.

For the purposes of establishing the upstream watershed area for confirming flows used in the design of the replacement access bridge as well as establishing the assessment schedule for the work, we investigated and reviewed the past Engineer's Reports on the 14th Concession West Drain as well as nearby Municipal Drains.

## V. FINDINGS AND RECOMMENDATIONS

From our investigations, it was determined that the existing access bridge is in poor condition and has limited service life remaining. Consequently, extending the structure is not a viable or cost-effective option. Based on our topographic survey, detailed investigations, examinations, and subsequent discussions with the abutting landowner, we would recommend that a new access bridge be constructed in the 14th Concession West Drain at the location and to the general parameters as established in our design drawings attached herein.

Prior to the completion of our Engineer's Report, we reviewed the details of the new replacement bridge with the landowner served by said bridge including preliminary cost estimates. It was established that the landowner would prefer a top width of approximately 9.14 meters (30.0 ft) with sloped quarried limestone on filter cloth end treatments which were determined to be the most cost effective option. It was confirmed that the replacement bridge should be located where the existing structure is currently located. From our investigations, it was determined that an 1800mm diameter, 2.0mm thick, Aluminized Steel Type II Corrugated Pipe is required based on minimum conveyance of the 2-year storm event. Additionally, the new culvert shall provide for a minimum of 10% pipe embedment for fish habitat and migration in accordance with regulatory restrictions.

As noted previously, during the course of our investigations, this project was discussed and reviewed with ERCA to deal with any concerns and comments related to the replacement access bridge over the 14th Concession West Drain. In accordance with "A Guide for Engineers Working Under the Drainage Act in Ontario" OMAFA (Publication 852), the 2-year design storm event was deemed the applicable level of service given that the drain serves a rural agricultural watershed and the bridge is considered a low-hazard field crossing. The selected pipe was sized to have the capacity to convey the the 2-year storm event based on our assessment of contributing flows from the upstream watershed area. Since the replacement access bridge is sized to meet the applicable level of service of the drain based on the upstream drainage area, it can reasonably be expected that said bridge will have no adverse flood impacts to the upstream drainage area.

As previously noted, the subject access bridge is located within a regulated area under the jurisdiction of ERCA, and therefore a permit or approval will be required by ERCA for the construction of the new replacement access bridge. Additionally, all work has to comply with the current mitigation provisions of ERCA. Details of these mitigation measures are included in the Specifications and Appendix "REI-A" forming part of this report.

As part of our investigations, a Department of Fisheries and Oceans (DFO) self screening assessment of the project was carried out by checking the DFO aquatic species at risk maps. The mapping indicated no species at risk or critical habitat within 1 kilometer of the subject replacement bridge location and therefore a formal project review from DFO is not required. In the interest of fish habitat and migration, should any species be encountered, details of required mitigation measures are included in the Specifications and Appendix "REI-A" forming part of this report.

A review of available information including a screening of Natural Heritage Information Centre (NHIC) data for Species at Risk (SAR) available through the web-based Natural Heritage Areas tool did not identify any species listed in the Protected Species in Ontario List regulation. Therefore, it is anticipated that the proposed drainage works will not result in any impacts to Species at Risk or their habitat and thus no permit or registration is required under the Species Conservation Act, 2025 at this time.

In the interest of Species at Risk, best management practices shall be undertaken to ensure the protection of any Species at Risk and their habitats throughout the course of construction. Additionally, under the now repealed Endangered Species Act (ESA), 2007, the Town of Essex had established comprehensive mitigation measures as well as species identification guides for reference. Although not required under the new SCA, these documents remain available for viewing at the Town office for those interested and copies of the measures and guides shall be provided to the awarded Tenderer.

Based on the foregoing, we recommend that a new replacement access bridge be constructed in the 14th Concession West Drain to serve the agricultural lands of Santo Farms Seed Company (600-05700), in South Part of Lot 2, Concession 14, in the former Geographic Township of Colchester North, in accordance with this Engineer's Report, the attached specifications and the accompanying drawings, and that all works associated with same be carried out in accordance with Section 78 of the "Drainage Act, R.S.O. 1990, Chapter D.17 as amended 2021".

#### **VI. ALLOWANCES AND COMPENSATION**

Since all of the work for the construction of the replacement access bridge shall be carried out from within and alongside the road allowance and limits of the drain as well as the immediate area surrounding the subject bridge, and because full restoration of said areas will be provided, we find that there is no requirement for allowances and compensation for damages pursuant to Sections 29 and 30 of the "Drainage Act, R.S.O. 1990, Chapter D.17 as amended 2010".

#### **VII. ESTIMATE OF COST**

Our estimate of the total cost of this work including all incidental expenses is the sum of **FIFTY SEVEN THOUSAND ONE HUNDRED EIGHTY ONE DOLLARS (\$57,181.00)**, made up as follows:

**CONSTRUCTION**

Item 1) Provide all labour, equipment and material to completely remove and dispose of the existing concrete span bridge structure and endwall materials, including any other deleterious material encountered and construct a new access bridge consisting of 18.0 metres (59.06 ft) of 1800mm diameter, 2.0mm thick, Aluminized Steel Type II Corrugated Pipe with annular ends, 125mm x 25mm corrugations and 9 corrugation bolted couplers including sloped quarried limestone on filter cloth end treatments, granular bedding and backfill, granular surface course and approaches, topsoil, seeding and mulching, excavation, compaction, hauling, cleanup and restoration, erosion and sediment control measures and traffic control measures, complete.

(Parcel 600-05700) Lump Sum \$ 37,200.00

Net H.S.T. (1.76%) \$ 655.00

**TOTAL FOR CONSTRUCTION** \$ **37,855.00**

**INCIDENTALS**

1) Report, Estimate, and Specifications \$ 7,000.00

2) Survey, Assistants, Expenses, Drawings \$ 7,000.00

3) Estimated Cost of Report and Drawings Duplication, Consideration Meeting and Court of Revision \$ 1,000.00

4) Estimated Cost of Preparing Tender and Contract Documents and Tender Review \$ 1,500.00

5) Estimated Cost of Construction Administration, Supervision and Inspection (estimated 2 days) \$ 2,000.00

6) Net H.S.T. on Items Above (1.76%) \$ 326.00

7) Estimated Cost of ERCA Input, Review and Authorizations \$ 500.00

**TOTAL FOR INCIDENTALS** \$ **19,326.00**

**TOTAL FOR CONSTRUCTION (brought forward)** \$ **37,855.00**

**TOTAL ESTIMATE** \$ **57,181.00**

### **VIII. DRAWINGS AND SPECIFICATIONS**

As part of this Engineer's Report, we have attached design drawings for the construction of the replacement access bridge. The design drawings show the alignment of the 14th Concession West Drain, the general location of the subject access bridge and the details of the new replacement access bridge. The design drawings are attached to the back of this report and are labelled **Appendix "REI-D"**.

Also attached, we have prepared Specifications, and Standard Specifications which set out the required construction details for the replacement access bridge within **Appendix "REI-C"**.

### **IX. CONSTRUCTION SCHEDULE OF ASSESSMENT**

We would recommend that all of the costs associated with the construction of this replacement access bridge, and the preparation of this Engineer's Report, be assessed against the agricultural lands of Santo Farms Seed Company (600-05700), in the South Part of Lot 2, Concession 14, and all upstream affected lands and roads in the Town of Essex. A Construction Schedule of Assessment has been prepared and included herein to indicate the lands and roads assessable for this replacement access bridge installation.

The cost sharing percentage between the landowner served by the subject access bridge and the upstream lands and roads affected by same has been established based on the location of said bridge relative to the entire reach of the drain. Additionally, the replacement access bridge has an increased top width beyond the standard 6.10 metre (20.0 ft) top width and thus all of the increased costs resulting from same shall be assessed 100% to the landowner served by said bridge, as provided for in the cost sharing set out in the attached Construction Schedule of Assessment.

It has been established that this replacement access bridge will provide access from 14th Concession road over the 14th Concession West Drain to the agricultural lands owned by Santo Farms Seed Company (600-05700). Pursuant to the latest Agricultural Drainage Infrastructure Program (ADIP) administrative policies currently in place, it is anticipated that these lands as well as upstream lands designated as "Farm Property Tax Class Rate" shall be eligible for a grant from the Ontario Ministry of Agriculture, Food and Agribusiness (OMAFRA) in the amount of 1/3 of their total assessment for this project.

### **X. FUTURE MAINTENANCE**

We recommend that the replacement access bridge identified herein, be maintained in the future as part of the 14th Concession West Drain. We further recommend that the subject bridge, for which the maintenance costs are to be shared with the affected upstream lands and roads within the watershed, be maintained by the Town of Essex and that said maintenance would include works to the bridge culvert, bedding, backfill and end treatments. Should concrete, asphalt, or

other decorative driveway surfaces over this bridge culvert require removal as part of the maintenance works, these surfaces shall also be repaired or replaced as part of said works. Likewise, if any fencing, gate, decorative walls, guardrails, or other special features exist that will be impacted by the maintenance works, they are also to be removed and restored or replaced as part of said works. However, the cost of the supply and installation of any surface materials other than Granular “A” material and the cost of removal and restoration or replacement, if necessary, of any special features, shall be totally assessable to the benefiting adjoining landowner served by said access bridge.

After the completion of all of the works provided for within this Engineer’s Report, the replacement access bridge within the 14th Concession West Drain shall be maintained in the future by the Town of Essex. Furthermore, if any maintenance work is required to this access bridge in the future, we recommend that 57.8% of the future maintenance costs be assessed as a Benefit assessment against the adjoining lands served by said access bridge which are currently owned by Santo Farms Seed Company (600-05700) in South Part of Lot 2, Concession 14, in the former Geographic Township of Colchester North. The remaining balance of 42.2% of the future maintenance costs be assessed pro-rata as an Outlet Liability assessment against the affected upstream lands and roads in the same proportions as provided for in the attached Schedule of Assessment. As noted above, these cost sharing percentages account for the replacement access bridge having an increased top width beyond the standard 6.10 metre (20.0 ft) top width that is normally shared between the adjoining landowner served by said access bridge and upstream affected lands and roads.

The above provisions for the future maintenance of this replacement access bridge, being constructed under this Engineer’s Report, shall remain as aforesaid until otherwise determined under the provisions of the “Drainage Act, R.S.O. 1990, Chapter D.17 as amended 2021”.

All of which is respectfully submitted,

***ROOD ENGINEERING INC.***



Gerard Rood, P.Eng.



DM/tm

Encl.

***ROOD ENGINEERING INC.***

Consulting Engineers  
9 Nelson Street  
LEAMINGTON, Ontario N8H 1G6



**CONSTRUCTION SCHEDULE OF ASSESSMENT**

**14TH CONCESSION WEST DRAIN**

**Town of Essex**

**3. MUNICIPAL LANDS:**

Tax Roll No.	Con. or Plan No.	Lot or Part of Lot	Hectares Owned	Acres Afft'd	Hectares Afft'd	Owner's Name	Value of Benefit	Value of Outlet	Value of Special Benefit	TOTAL VALUE
		14th Concession Road		24.70	9.996	Town of Essex	\$ -	\$ 4,054.00	\$ -	\$ 4,054.00
		County Road 15		5.64	2.283	County of Essex	\$ -	\$ 926.00	\$ -	\$ 926.00
		Walker Sideroad		3.38	1.369	Town of Essex	\$ -	\$ 555.00	\$ -	\$ 555.00
<b>Total on Municipal Lands.....</b>							<b>\$ -</b>	<b>\$ 5,535.00</b>	<b>\$ -</b>	<b>\$ 5,535.00</b>

**4. PRIVATELY OWNED - NON-AGRICULTURAL LANDS:**

Tax Roll No.	Con. or Plan No.	Lot or Part of Lot	Hectares Owned	Acres Afft'd	Hectares Afft'd	Owner's Name	Value of Benefit	Value of Outlet	Value of Special Benefit	TOTAL VALUE
580-02006	13	PT LOT 10	1.570	3.88	1.570	Judy & David Santo	\$ -	\$ 208.00	\$ -	\$ 208.00
590-01200	14	W PT LOT 5	0.449	1.11	0.449	Maurice & Monica Trepanier	\$ -	\$ 96.00	\$ -	\$ 96.00
590-02420	14	PT LOT 8	0.406	1.00	0.406	Annik White & Joseph Van Vrouwerff	\$ -	\$ 87.00	\$ -	\$ 87.00
590-02450	14	PT LOT 8	0.401	0.99	0.401	Dayna Debruyne	\$ -	\$ 89.00	\$ -	\$ 89.00
590-02500	14	W PT LOT 5	0.383	0.95	0.383	Marilyn O'neil	\$ -	\$ 85.00	\$ -	\$ 85.00
590-03400	13	N PT LOT 8	0.389	0.96	0.389	Johanna Kerekes	\$ -	\$ 86.00	\$ -	\$ 86.00
600-05250	14	W PT LOT 3	0.402	0.99	0.402	Kristopher & Amy Tehan	\$ -	\$ 89.00	\$ -	\$ 89.00
600-05300	14	PT LOT 3	0.259	0.64	0.259	Joseph & Diane Meloche	\$ -	\$ 63.00	\$ -	\$ 63.00
600-05400	14	PT LOT 3	0.130	0.32	0.130	Brendan McGhee & Jaycie Stanek	\$ -	\$ 37.00	\$ -	\$ 37.00
600-05601	14	PT LOT 4	0.348	0.86	0.348	Barry & Dianne Kemp	\$ -	\$ 80.00	\$ -	\$ 80.00
600-05603	14	PT LOT 4	0.306	0.75	0.306	Zeina & Charlie Youssef	\$ -	\$ 72.00	\$ -	\$ 72.00
<b>Total on Privately Owned - Non-Agricultural Lands.....</b>							<b>\$ -</b>	<b>\$ 992.00</b>	<b>\$ -</b>	<b>\$ 992.00</b>

**5. PRIVATELY OWNED - AGRICULTURAL LANDS (grantable):**

Tax Roll No.	Con. or Plan No.	Lot or Part of Lot	Hectares Owned	Acres Afft'd	Hectares Afft'd	Owner's Name	Value of Benefit	Value of Outlet	Value of Special Benefit	TOTAL VALUE
580-01200	13	N PT LOT 9	19.295	25.81	10.444	Gerald & Michelle Santo	\$ -	\$ 770.00	\$ -	\$ 770.00
580-01300	14	PT LOT 9	19.692	48.66	19.692	Brian Market	\$ -	\$ 1,452.00	\$ -	\$ 1,452.00
580-01301	14	PT LOT 9	20.608	50.92	20.608	Brian & Michelle Market	\$ -	\$ 1,520.00	\$ -	\$ 1,520.00
580-01400	14	PT LOT 10	20.265	50.08	20.265	Luanne Weston & Ronald Lafferty	\$ -	\$ 1,494.00	\$ -	\$ 1,494.00
580-01500	14	PT LOT 10	20.666	51.07	20.666	John Lafferty & Marianne Fetherston	\$ -	\$ 1,524.00	\$ -	\$ 1,524.00
580-02102	13	PT LOT 9 & 10	56.365	20.49	8.290	David & Judy Santo, 734032 Ontario Ltd.	\$ -	\$ 611.00	\$ -	\$ 611.00
590-01600	14	W PT LOT 5	8.157	20.16	8.157	Zheng Fu Mao	\$ -	\$ 601.00	\$ -	\$ 601.00
590-02090	14	PT LOT 5	20.017	49.46	20.017	Joslyne Rizza	\$ -	\$ 1,476.00	\$ -	\$ 1,476.00
590-02200	14	PT LOT 6	22.702	56.10	22.702	John Lafferty & Joslyne Rizza	\$ -	\$ 1,674.00	\$ -	\$ 1,674.00
590-02250	14	PT LOT 6	18.818	46.50	18.818	Parrline Supply Limited	\$ -	\$ 1,388.00	\$ -	\$ 1,388.00
590-02300	14	PT LOT 7	20.154	49.80	20.154	Santo Farms Seed Company	\$ -	\$ 1,486.00	\$ -	\$ 1,486.00
590-02305	14	PT LOT 7	20.657	51.04	20.657	David Fantinato & Teresa Novelletto	\$ -	\$ 1,523.00	\$ -	\$ 1,523.00
590-02400	14	PT LOT 8	20.944	51.75	20.944	Brian & Michelle Market	\$ -	\$ 1,544.00	\$ -	\$ 1,544.00
590-02410	14	PT LOT 8	20.047	49.54	20.047	Brian & Michelle Market	\$ -	\$ 1,478.00	\$ -	\$ 1,478.00
590-02495	14	PT LOT 5	9.689	23.94	9.689	Nicole & Michelle Levasseur	\$ -	\$ 714.00	\$ -	\$ 714.00
590-03500	13	PT LOT 8	30.194	43.25	17.502	Chad & Donald Quinlan	\$ -	\$ 1,291.00	\$ -	\$ 1,291.00
600-05200	14	W PT LOT 3	19.921	49.22	19.921	Rosemary Meloche	\$ -	\$ 1,469.00	\$ -	\$ 1,469.00
600-05500	14	PT LOT 3	20.230	49.99	20.230	Justine Meloche	\$ -	\$ 1,492.00	\$ -	\$ 1,492.00
600-05600	14	PT LOT 4	20.300	50.16	20.300	Louis & Dobrilla Stankovich	\$ -	\$ 1,497.00	\$ -	\$ 1,497.00
600-05620	14	PT LOT 4	20.610	50.93	20.610	Ljuba & Ljuban Stankovich & Milanka Dobrich	\$ -	\$ 1,520.00	\$ -	\$ 1,520.00
600-05700	14	S PT LOT 2	19.089	0.00	0.000	Santo Farms Seed Company	\$ 24,130.00	\$ -	\$ -	\$ 24,130.00
<b>Total on Privately Owned - Agricultural Lands (grantable).....</b>							<b>\$ 24,130.00</b>	<b>\$ 26,524.00</b>	<b>\$ -</b>	<b>\$ 50,654.00</b>
<b>TOTAL ASSESSMENT</b>				<b>935.03</b>	<b>378.40</b>		<b>\$ 24,130.00</b>	<b>\$ 33,051.00</b>	<b>\$ -</b>	<b>\$ 57,181.00</b>

1 Hectare = 2.471 Acres

## **SPECIFICATIONS**

### **14TH CONCESSION DRAIN WEST**

#### **Replacement Bridge for Santo Farms Seed Company (600-05700)**

#### **Geographic Township of Colchester North**

### **TOWN OF ESSEX**

#### **I. GENERAL SCOPE OF WORK**

The 14th Concession West Drain is an open drain with a number of access bridges constructed pursuant to the Drainage Act, and begins upstream in Lot 10, Concession 14 and continues westerly along the north side of the 14th Concession Road where it then heads southerly for a short distance on the east side of Walker Road (County Road 11) where it outlets into the Shuell Creek Drain in the Town of Amherstburg.

The work under this project generally comprises of the removal of an existing access bridge structure and construction of a new replacement access bridge serving the lands of Santo Farms Seed Company (600-05700). More specifically, the work on said bridge includes all labour, equipment and material to completely remove and dispose of the existing concrete span bridge structure and endwall materials, including any other deleterious material encountered and construct a new access bridge consisting of 18.0 metres (59.06 ft) of 1800mm diameter, 2.0mm thick, Aluminized Steel Type II Corrugated Pipe with annular ends, 125mm x 25mm corrugations and 9 corrugation bolted couplers including sloped quarried limestone on filter cloth end treatments, granular bedding and backfill, granular surface course and approaches, topsoil, seeding and mulching, excavation, compaction, hauling, cleanup and restoration, erosion and sediment control measures and traffic control measures.

All work shall be carried out in accordance with these Specifications and Special Provisions, the design drawings within **Appendix "REI-D"**, as well as the Standard Specifications and Details included in **Appendix "REI-C"**. The new replacement bridge construction shall be of the size, type, depth, etc. as shown in the noted design drawings, as determined from the benchmarks, and as may be further laid out at the subject site at the time of construction. All work carried out under this project shall be completed to the full satisfaction of the Town Drainage Superintendent and/or the Consulting Engineer.

#### **II. ERCA AND DFO CONSIDERATIONS**

The Contractor will be required to implement stringent erosion and sediment control measures during the course of the work to minimize the amount of silt and sediment being carried downstream. It is intended that work on this project be carried out during relatively dry weather to ensure proper site and drain conditions so as to avoid conflicts with sediment being deposited

into the outlet drainage system. All disturbed areas shall be restored as quickly as possible with grass seeding and mulching, or approved equivalent, installed to ensure a protective cover do as to minimize any erosion from the working area subsequent to construction. The Contractor may be required to provide temporary silt fencing and straw bales as outlined further in these specifications.

All of the work shall be carried out in accordance with the documentation provided in **Appendix “REI-A”** as well as any permits or authorizations issued by the Essex Region Conservation Authority (ERCA) or the Department of Fisheries and Oceans (DFO), copies of which will be provided, if available. The Contractor is advised that no work may be carried out in the existing drain from March 15th to July 15th of any given year.

In addition to the above, as part of its work, the Contractor shall implement the following measures that will ensure that any potential adverse effects on fish and fish habitat will be mitigated:

- a) As per standard requirements, work will not be conducted at times when flows in the drain are elevated due to local rain events, storms, seasonal floods or otherwise. Work will be done in the dry.
- b) All disturbed soils on the drain banks and within the channel, including spoil, must be stabilized immediately upon completion of work. The restoration of the subject site must be completed to a like or better condition to what existed prior to the works. The spoil material must be hauled away and disposed of at a suitable site or spread an appropriate distance from the top of the drain bank to ensure that it is not washed back into the drain.
- c) To prevent sediment entry into the drain, in the event of an unexpected rainfall or otherwise, silt barriers and/or traps must be placed in the channel during the works and until the subject site has been stabilized. All sediment and erosion control measures are to be in accordance with applicable Ontario Provincial Standards. It is incumbent on the proponent and its Contractors to ensure that sediment and erosion control measures are functioning properly and are maintained and upgraded as required.
- d) Silt or sand accumulated in the barrier traps must be removed and stabilized on land once the site is stabilized.
- e) All activities including maintenance procedures should be controlled to prevent the entry of petroleum products, debris, rubble, concrete, or other deleterious substances into the water. Vehicular refuelling and maintenance should be conducted away from the water.

### **III. MECP CONSIDERATIONS**

As of March 30th, 2026, the Endangered Species Act (ESA), 2007 has been replaced by the Species Conservation Act (SCA), 2025 administered by the Ministry of Environment, Conservation and Parks (MECP). Under the now repealed ESA, exemption provisions of Section 23.9 of Ontario Regulation 242/08 allowed the Town to carry out repairs, maintenance and improvements within existing Municipal Drains. These works were exempt from Sections 9 and 10 of the ESA provided that the rules in the regulations were followed. If eligible, the exemption provisions of the legislation allowed the Town to give notice to the Ministry by registering their drainage activities through an online registry system. Under the new SCA, drainage works are no longer excepted, and the Town needs to register drainage activities, that will, or are likely to, impact species listed on the Protected Species in Ontario List regulation or their habitat.

It is anticipated that the proposed drainage works will not result in any impacts to Species at Risk or their habitat and thus no permit or registration is required under the Species Conservation Act, 2025 at this time. In the interest of Species at Risk, best management practices shall be undertaken to ensure the protection of any Species at Risk and their habitats throughout the course of construction. Additionally, under the now repealed Endangered Species Act (ESA), 2007, the Town of Essex had established comprehensive mitigation measures as well as species identification guides for reference. Although not required under the new SCA, these documents remain available for viewing at the Town office for those interested and copies of the measures and guides shall be provided to the Contractor.

The Contractor shall review these documents in detail and is required to comply in all regards with the contents and follow the special requirements therein included during construction. Throughout the course of construction, the Contractor will be responsible to ensure that all necessary provisions are undertaken to protect all Species at Risk and their habitats. If a Species at Risk or habitat is encountered, the Contractor shall immediately notify the Town Drainage Superintendent, the Consulting Engineer and the MECP and provide all of the equipment and materials required by the mitigation requirements for handling said species and cooperate fully with the Town and MECP staff in the handling of the species.

### **IV. ACCESS TO WORK**

The Contractor is advised that the majority of the work to be carried out on this project extends along the north side of the 14th Concession Road. The Contractor shall have access for the full width of the roadway abutting the proposed drainage works. The Contractor may utilize the right-of-way as necessary, to permit the completion of all of the work required to be carried out for this project. The Contractor shall also have access into the driveways along with a sufficient area in the vicinity of the subject access bridge as necessary to complete the work to be carried out on this project, as set out in the design drawings and in these Specifications.

**V. TRAFFIC CONTROL**

The Contractor shall ensure that the traveling public is protected at all times while utilizing the roadway for its access. The Contractor shall provide traffic control, including flag persons when required. Should the Contractor have to close the 14th Concession Road for the proposed works, it shall obtain the permission of the Town Drainage Superintendent and/or Consulting Engineer and arrange to provide the necessary notification of detours around the site. The Contractor shall also ensure that all emergency services, school bus companies, etc. are contacted about the disruption to access at least 48 hours in advance of same. All detour routes shall be established in consultation with the Road Authority.

Throughout the course of the work, it is imperative that the Contractor protect as much landscaping and vegetation as possible when accessing along the drain. Due to the extent of the work and the area for carrying out the work, the Contractor will be required to carry out all of the necessary steps to direct traffic and provide temporary diversion of traffic around work sites, including provision of all lights, signs, flag persons, and barricades required to protect the safety of the traveling public. Any accesses or areas used in carrying out the works are to be fully restored to their original conditions by the Contractor at its cost, including topsoil placement and lawn restoration as directed by the Town Drainage Superintendent and/or the Consulting Engineer. Restoration shall include but not be limited to all necessary levelling, grading, shaping, topsoil, seeding, mulching, and granular placement required to make good any damage caused.

**VI. REMOVAL OF BRUSH, TREES AND RUBBISH**

Where there is any brush, trees or rubbish along the course of the drainage works, including the full width of the work access, all such brush, trees or rubbish shall be close cut and grubbed out, and the whole shall be chipped up for recycling, burned or otherwise satisfactorily disposed of by the Contractor. The brush and trees removed along the course of the work are to be put into piles by the Contractor in locations where they can be safely chipped and disposed of, or burned by it, or hauled away and disposed of by the Contractor to a site to be obtained by it at its expense. Prior to and during the course of any burning operations, the Contractor shall comply with the guidelines prepared by the Air Quality Branch of the Ontario Ministry of the Environment, Conservation and Parks (MECP) and shall ensure that the Environmental Protection Act is not violated. The Contractor will be required to notify the local Fire Authorities to obtain any permits and co-operate with them in the carrying out of any work. The removal of brush and trees shall be carried out in close consultation with the Town Drainage Superintendent and/or Consulting Engineer to ensure that no decorative trees or shrubs are disturbed by the operations of the Contractor that can be saved. It is the intent of this project to save as many trees and bushes as practical within the roadway allowances and on private lands. Where decorative trees or shrubs are located directly over drainage pipes, the Contractor shall carefully extract same and turn them over to the Owner when requested to do so and shall cooperate with the Owner in the reinstallation of same if required.

The Contractor shall protect all other trees, bushes, and shrubs located along the length of the drainage works except for those trees that are established, in consultation with the Town Drainage Superintendent, the Consulting Engineer, and the Owners, to be removed as part of the works. The Contractor shall note that protecting and saving the trees may require the Contractor to carry out hand work around the trees, bushes, and shrubs to complete the necessary final site grading and restoration.

Following the completion of the work, the Contractor is to trim up any broken or damaged limbs on trees which are to remain standing, and it shall dispose of said branches along with other brush, thus leaving the trees in a neat and tidy condition. All such deleterious materials and rubbish shall be loaded up and hauled away by the Contractor to a site to be obtained by it at its cost.

## **VII. REMOVALS**

Where the existing access bridge is to be completely removed and replaced, the Contractor shall be required to excavate and completely extract the existing culvert pipe and the existing endwalls in their entirety, as well as any other deleterious materials that may be encountered in removing same. The Contractor shall also be required to completely dispose of all removed materials to a site to be obtained by it at its own expense.

All unsuitable and deleterious materials from the excavation and removal of the existing bridge culvert and drain cleaning shall be hauled away and disposed of by the Contractor to a site to be obtained by it at its expense. Likewise, any material excavated to allow for the granular approaches to the bridge, driveway transitions, and installation of new headwalls shall also be hauled away and disposed of by the Contractor.

## **VIII. DETAILS OF BRIDGE WORK**

The Contractor shall provide all material, labour and equipment to completely remove the existing access bridge in the 14th Concession West Drain and construct a new replacement access bridge along with end treatments and ancillary work.

The existing access bridge slated to be removed shall be replaced with 18.0 metres (59.06 ft) of 1800mm diameter, 2.0mm thick, Aluminized Steel Type II Corrugated Pipe with annular ends, 125mm x 25mm corrugations and 9 corrugation bolted couplers. The new replacement bridge shall have sloped quarried limestone on filter cloth end treatment at both ends

The new pipe installation on this project shall be set to the grades as shown on the design drawings or as otherwise established herein and the Town Drainage Superintendent and/or the Consulting Engineer may make minor changes to the bridge alignment as they deem necessary to suit the subject site conditions. All work shall be carried out in accordance with these

Specifications and Special Provisions, the design drawings within Appendix “REI-D”, as well as the “STANDARD SPECIFICATIONS FOR ACCESS BRIDGE CONSTRUCTION” attached to this report and labelled Appendix “REI-C”. The new replacement bridge construction shall be of the size, type, depth, etc. as shown in the noted design drawings, as determined from the benchmarks, and as may be further laid out at the subject site at the time of construction. All work carried out shall be completed to the full satisfaction of the Town Drainage Superintendent and/or the Consulting Engineer.

#### **IX. CORRUGATED STEEL PIPE INSTALLATION**

The new Corrugated Steel Pipe (CSP) to be installed on this project is required to be provided in the longest lengths that are available and shall not be less than 3.0 metres. Where the overall access pipe length exceeds the standard pipe lengths, the Contractor shall connect the pipe sections together by use of a manufactured 9-C bolted coupler installed in accordance with the manufacturer’s recommendations. All coupler joints shall be wrapped with a layer of filter cloth around its complete circumference so that it extends a minimum of 100mm beyond the coupler on each end, to ensure that there will be no soil migration through the joints and into the pipe through said connections.

The Contractor shall note that the placement of any new culvert pipe shall be performed totally in the dry and it shall be prepared to take whatever steps are necessary to ensure same, all to the full satisfaction of the Town Drainage Superintendent and/or the Consulting Engineer. As part of the work, the Contractor will be required to clean out the drain along the full length of the pipe and for a distance of 3.05 metres (10.0 ft) upstream and downstream of the pipe. The design parameters of the 14th Concession West Drain at the location of the replacement access bridge installation consists of a 1.22 metres (4.0 ft) bottom width, the grade shown on the profile within the design drawings, and 1.5 horizontal to 1.0 vertical sideslopes. The Contractor shall note that the pipe inverts are set at least 10% of the pipe diameter or rise below the drain bottom to provide the embedment for fish habitat and migration in accordance with regulatory restrictions.

The installation of the complete length of the new culvert pipe, including all appurtenances, shall be completely inspected by the Town Drainage Superintendent and/or the Consulting Engineer’s Inspector prior to backfilling any portions of same. Under no circumstance shall the Contractor commence the construction or backfill of the new culvert pipe without the site presence of the Town Drainage Superintendent and/or the Consulting Engineer’s Inspector to inspect and approve said installation. The Contractor shall provide a minimum of two (2) working days’ notice to the Town Drainage Superintendent and the Consulting Engineer prior to commencement of the work. The installation of the new culvert structure is to be performed during normal working hours of the Town Drainage Superintendent and the Consulting Engineer from Monday to Friday unless written authorization is provided by them to amend said working hours.

For the access bridge installation, once the new Aluminized Steel Type II Corrugated Pipe has been satisfactorily set in place, the Contractor shall completely backfill same with granular

material MTO Type “B” OPSS Form 1010 with the following exception. The top 305mm (12”) of the backfill material for the full top width of the access, and the full top width of the drain or the excavated trench, and any approaches and transitions shall be granular material MTO Type “A” OPSS Form 1010. All of the driveway approach areas extending from the roadway to the new bridge culvert shall be backfilled with compacted granular material MTO Type “A” OPSS Form 1010, but only after all topsoil material has been completely removed and disposed of, and the minimum thickness of this granular material shall be 305mm (12”). All areas outside of the access driveway shall be backfilled with native material compacted to 96% of Standard Proctor Density and topped with a minimum of 100mm of topsoil and shall be seeded and mulched, or approved equivalent.

For hard surface driveway crossings, the top 305mm (12”) of the backfill over the pipe below the hard surface treatment shall comprise granular material MTO Type “A” OPSS Form 1010 compacted to a minimum of 100% Standard Proctor Density. The Contractor shall at all times be very careful when performing its backfilling and compaction operations so that no damage is caused to the pipe. To ensure that no damage is caused to the proposed pipe, alternative methods of achieving the required backfill compaction shall be submitted to the Consulting Engineer or the Town Drainage Superintendent for their approval prior to the commencement of this work. The Contractor shall restore the asphalt surface by placing a minimum of the existing thickness or a 90mm minimum thickness of Type HL-4 hot mix asphalt. The asphalt shall be supplied and placed in two (2) approximately equal lifts compacted to a value ranging from 92% to 96% of maximum relative density as per OPSS 310. For existing concrete driveways, the Contractor shall carefully remove the concrete to the nearest expansion joint. The concrete driveway shall be restored to the original length and width that was removed and include 150mm thick, 30MPa concrete, with 6% ±1% air entrainment and 6x6-6/6 welded wire fabric reinforcing installed at the midpoint of the slab. All slab surfaces shall be finished to provide an appearance approximating the finish on the existing concrete driveway abutting the replacement.

The Contractor will be responsible to restore any damage caused to the roadways at its cost. All damaged hard surface roadway areas shall be neatly saw cut and the damaged materials removed and disposed of by the Contractor prior to carrying out any restoration work. The extent of the repairs shall be established in consultation with the Town Drainage Superintendent, the Road Authority, and the Consulting Engineer and the repairs shall be completed to their full satisfaction.

The Contractor is to note that any intercepted pipes or tiles along the length of the proposed culvert are to be extended and connected at its cost to the open drain at the end of the new culvert unless otherwise noted in the accompanying drawings.

The Contractor shall also note that the placing of the new access bridge culvert shall be completed so that it totally complies with the parameters established and noted in these Specifications and accompanying design drawing for the culvert replacement. The culvert shall be set on an even grade, and the placement shall be performed totally in the dry, and the Contractor should be prepared to take whatever steps are necessary to ensure same, all to the full satisfaction of the Town Drainage Superintendent and/or the Consulting Engineer. The

Contractor shall also be required to supply a minimum of 100mm (4") of 20mm (3/4") clear stone bedding underneath the culvert pipe extending from the bottom of the drain to the culvert invert grade, all to the full satisfaction of the Town Drainage Superintendent and/or the Consulting Engineer. Furthermore, if an unsound base is encountered, it must be removed and replaced with 20mm (3/4") clear stone satisfactorily compacted in place to the full satisfaction of the Town Drainage Superintendent and/or the Consulting Engineer. The Contractor is to note that when replacing an access bridge or enclosure culvert, it shall be required to excavate a trench having a width not less than the new pipe outside diameter plus a 600mm working width on both sides of the new pipe to allow for proper installation of granular backfill and compaction of same. The Contractor shall also note that all culvert pipe installations are to be carried out with a minimum of 10% of their diameter or rise embedded below the drain design bottom, as noted in these Specifications and shown in the accompanying design drawings for the access bridge installation.

**X. CONCRETE FILLED JUTE BAG, PRECAST CONCRETE BLOCK OR SLOPED END TREATMENT**

Unless otherwise shown or noted, the Contractor is to provide new concrete filled jute bag headwalls, precast concrete block, or sloped quarried limestone on non-woven filter cloth end treatments for the access bridge being replaced or constructed on this drain.

The concrete filled jute bags are to be provided and laid out as shown and detailed in the provided design drawings and as noted in the Standard Specifications in **Appendix "REI-C"**. In all cases, the concrete filled jute bag headwalls shall be topped with a minimum 100mm (4") thick continuous concrete cap comprising 30mPa concrete with 6% ±1% air entrainment for the entire length of the headwalls. The headwalls shall be installed on an inward batter to be not less than 1 horizontal to 5 vertical, and under no circumstances shall this batter, which is measured from the top of the headwall to the projection of the end of the pipe, be less than 305mm (12"). From the midpoint of the pipe height down to the concrete footing, the wall shall be a double concrete filled jute bag installation. On the roadside the walls shall be deflected as shown to provide daylighting and a better approach across the new bridge.

The installation of the concrete filled jute bag headwalls, unless otherwise specified, shall be provided in total compliance with Items 1, 3, and 4 included in the **"STANDARD SPECIFICATIONS FOR ACCESS BRIDGE CONSTRUCTION"**, which is attached to the back of these Specifications and labelled **Appendix "REI-C"**. The Contractor shall comply in all respects with the General Conditions included in Item 4 and the **"Typical Concrete Filled Jute Bag Headwall End Protection"** detail also included therein.

The Contractor shall install interlocking precast concrete blocks with filter cloth backing for walls on both ends of the bridge requiring same. The blocks shall be minimum 600x600x1200mm in size as available from Underground Specialties - Wolseley, Windsor, Ontario, or approved equivalent, and installed as set out in **Appendix "REI-C"**. Vertical joints shall be staggered by use of half blocks where needed and wingwall deflections when required shall employ 45-degree angled blocks. The block supplier shall provide shop drawings of the headwall block layout for

review by the Consulting Engineer that includes blocks shaped for a close fit around the bridge pipe. Voids between the blocks and the pipe shall be grouted with 30MPa concrete having 6% ±1% air entrainment and extend for the full thickness of the wall and have a smooth uniform finish on the face that blends with the precast blocks. The installation of the endwalls, as well as the backfilling of the pipe where applicable, shall be provided in compliance with Items 1, 3, and 4 of the **“STANDARD SPECIFICATIONS FOR ACCESS BRIDGE CONSTRUCTION”** attached within **Appendix “REI-C”** and in total compliance and in all respects with the General Conditions also included therein. The Contractor shall submit shop drawings for approval of the wall installation that includes details for a minimum 300mm thick reinforced precast concrete footing that extends from the pipe invert downward. The reinforced precast footing shall extend for the full bottom width of the drain and into the drain banks each side for the required 300mm of embedment of the blocks and be constructed and installed to ensure that the completed wall will be completely vertical or tipped slightly back towards the driveway. Where the block walls extend more than 1.8 metres in height, the supplier shall provide the Contractor with uni-axial geogrid (SG350 or equivalent) reinforcement for installation to tie the wall back into the granular backfill. The Contractor, in all cases, shall comply with these specifications and upon completion of the stacked precast concrete wall installation shall restore the adjacent areas to their original conditions. The Contractor shall supply quarried limestone on filter cloth rock protection adjacent to the headwalls at each corner of the bridge. All rock protection shall be 1.0 metres wide and 305mm (12”) thick, installed on non-woven filter cloth from top of the drain bank to the bottom bank of the drain, and shall be installed in accordance with Item 2 of the **“STANDARD SPECIFICATIONS FOR ACCESS BRIDGE CONSTRUCTION”**. The synthetic filter mat to be used shall be non-woven geotextile GMN160 conforming to OPSS 1860 Class I, as available from Armtex Construction Products through Underground Specialties - Wolseley in Windsor, Ontario or approved equivalent. The quarried limestone to be used shall be graded in size from a minimum of 100mm to a maximum of 250mm, and is available from Walker Industries Amherst Quarries, in Amherstburg, Ontario, or approved equivalent.

Where sloped end protection is specified, the top 305mm (12”) of backfill material over the ends of the access pipe, from the invert of said pipe to the top of the driveway elevation of the access bridge or enclosure, shall be quarried limestone. The quarried limestone shall be provided as shown and detailed on the design drawings or as indicated in the Standard Specifications in **Appendix “REI-C”** and shall be graded in size from a minimum of 100mm (4”) to a maximum of 250mm (10”). The quarried limestone to be placed on the sloped ends of an access bridge or enclosure shall be underlain with a synthetic non-woven geotextile filter fabric. The sloped quarried limestone protection is to be rounded as shown on the plan details and shall also extend along the drain side slopes to a point directly in line with the ends of the culvert pipe. The roadside approach to the entrance shall be provided with a minimum 5.0m radius at each end of the driveway entrance. All work shall be completed to the full satisfaction of the Town Drainage Superintendent and/or the Consulting Engineer.

The installation of the sloped quarried limestone end protection, unless otherwise specified, shall be provided in total compliance with Items 1, 3, and 4 included in the **“STANDARD SPECIFICATIONS FOR ACCESS BRIDGE CONSTRUCTION”**, which is attached to the back of these

Specifications and labelled **Appendix “REI-C”**. The Contractor shall comply in all respects with the General Conditions included in Item 4 and the **“Typical Concrete Filled Jute Bag Headwall End Protection”** detail also included therein.

The quarried limestone erosion protection shall be embedded into the sideslopes of the drain a minimum thickness of 305mm and shall be underlain in all cases with non-woven synthetic filter mat. The filter mat shall not only be laid along the flat portion of the erosion protection but also contoured to the exterior limits of the quarried limestone and the unprotected slope. The width of the erosion protection shall be as established in the accompanying drawings or as otherwise directed by the Town Drainage Superintendent and/or the Consulting Engineer during construction. In placing the erosion protection, the Contractor shall carefully tamp the quarried limestone pieces into place with the use of the excavator bucket so that the erosion protection when completed will be consistent, uniform and tightly laid. In no instance shall the quarried limestone protrude beyond the exterior contour of the unprotected drain sideslopes along either side of said protection. The synthetic filter mat fabric to be used shall be non-woven geotextile GMN160 conforming to OPSS 1860 Class I, as available from Armtex Construction Products, or approved equivalent. The quarried limestone to be used shall be graded in size from a minimum of 100mm to a maximum of 250mm, and is available from Walker Aggregates Amherst Quarries, in Amherstburg, Ontario, or approved equivalent.

#### **XI. BENCHMARKS**

Also, for use by the Contractor, we have established a Benchmark at the location where the existing access bridge is being replaced. For each of the bridge replacements, the accompanying design drawings include details illustrating the work to be carried out and indicate a Benchmark and Elevation which may be utilized by the Contractor in carrying out its work. The Contractor shall note that in each case a specific design elevation grade has been provided for the invert at each end of the pipe in the profile accompanying each detail. The profile also sets out the pipe size, materials, and other requirements relative to the installation of the culvert structure. In all cases, the Contractor is to utilize the specified drain grade to set any new pipe installation. The Contractor shall ensure that it takes note of the direction of flow and sets all pipes to assure that all grades flow to match the direction of flow within the drain. The Contractor’s attention is drawn to the fact that the pipe invert grades established herein provide for the pipes to be set at least 10% of their diameter or pipe rise below the existing drain bottom or the design grade of the drain, whichever is lower.

#### **XII. ANCILLARY WORK**

During the course of any work to the bridge along the length of the project, the Contractor will be required to protect or extend any existing tile ends or swales and connect them to the drainage works to maintain the drainage from the adjacent lands. All existing tiles shall be extended utilizing solid Big ‘O’ “standard tile ends” or equal plastic pipe of the same diameter as

the existing tile and shall be installed in accordance with the **“Standard Lateral Tile Detail”** included in the plans, unless otherwise noted. Connections shall be made using a manufacturer’s coupling where possible. Wherever possible, tiles shall be extended to outlet beyond the end of the access culvert. When required, openings into new pipes shall be neatly bored, saw cut or burned with a torch to the satisfaction of the Town Drainage Superintendent and/or the Consulting Engineer. All cuts to steel pipes shall be touched up with a thick coat of zinc rich paint (Galvicon or approved equivalent) in accordance with the manufacturer’s recommendations. For other connections, the Contractor shall utilize a grouted connection. Grouted mortar joints shall be composed of three (3) parts of clean, sharp sand to one (1) part of Portland cement with just sufficient water added to provide a stiff plastic mix, and the mortar connection shall be performed to the full satisfaction of the Town Drainage Superintendent and/or the Consulting Engineer. The mortar joint shall be of a sufficient mass around the full circumference of the joint on the exterior side to ensure a tight, solid seal. The Contractor is to note that any intercepted pipes along the length of the existing culvert are to be extended and connected to the open drain unless otherwise noted in the accompanying drawings.

Where the bridge installation interferes with the discharge of an existing swale, the Contractor shall re-grade the existing swale to allow for the surface flows to freely enter the drain. Any disturbed grass areas shall be fully restored with topsoil, seed and mulch.

All granular backfill for the bridge installation shall be satisfactorily compacted in place to a minimum Standard Proctor Density of 98% by means of mechanical compaction equipment. All other good, clean, native fill material or topsoil to be utilized, where applicable, shall be compacted in place to a minimum Standard Proctor Density of 95%. All of the backfill material, equipment used, and method of compacting the backfill material shall be provided and performed to the full satisfaction of the Town Drainage Superintendent and/or Consulting Engineer.

The Contractor will be responsible to restore any damage caused to driveways at its cost. All damaged hard surface driveway areas shall be neatly saw cut and the damaged materials removed and disposed of by the Contractor prior to carrying out any restoration work.

The new corrugated Aluminized Steel Type II Corrugated Pipe for this installation is to be provided with a minimum depth of cover measured from the top of the pipe of 305mm (12") for a round pipe and 500mm for a pipe arch or as otherwise specified in OPSD 805.010 and OPSD 805.020 respectively. If the bridge culvert pipes are placed at their proper elevations, same or greater cover depths should be achieved. If the Contractor finds that the minimum cover is not being met, they shall notify the Town Drainage Superintendent and the Consulting Engineer immediately so that steps can be taken to rectify the condition prior to the placement of any backfill. The minimum cover requirement is critical and must be attained. In order for this new access bridge culvert to properly fit the channel parameters, all of the design grade elevations must be strictly adhered to.

As a check, all of the above access bridge culvert design grade elevations should be confirmed before commencing to the next stage of the access bridge installation. The Contractor is also to check that the pipe invert grades are correct by referencing the Benchmark.

Although it is anticipated that the culvert installation shall be undertaken in the dry, the Contractor shall supply and install a temporary straw bale or silt curtain check dam in the drain bottom immediately downstream of each culvert site during the time of construction in accordance with applicable Ontario Provincial Standards Specifications. The straw bale or silt curtain check dam shall be to the satisfaction of the Town Drainage Superintendent and/or Consulting Engineer and must be removed upon completion of the construction. The check dam materials may be reused at each site subject to their condition. All costs associated with the supply and installation of this straw bale or silt curtain check dam shall be included in the cost bid for the bridge replacement.

### **XIII. TOPSOIL, SEED AND MULCH**

The Contractor shall be required to restore all existing grassed areas and drain side slopes damaged by the bridge replacement, construction or cutting of the drain cross section, by placing topsoil, and then seed and mulch, or approved equivalent, over said areas including any specific areas noted on the bridge details. The Contractor shall be required to provide all the necessary material to cover the above mentioned surfaces with approximately 50mm of good, clean, dry topsoil on slopes and 100mm of good, clean, dry topsoil on horizontal surfaces, fine graded and spread in place ready for seeding and mulching. The placing and grading of any topsoil shall be carefully and meticulously carried out in accordance with Ontario Provincial Standard Specifications, Form 802 dated November 2010, or as subsequently amended, or as amended by these Specifications and be readied for the seeding and mulching process. The seeding and mulching of all of the above mentioned areas shall comply in all regards to Ontario Provincial Standard Specifications, Form 803 dated November 2010 and Form 804, dated November 2013, or as subsequently amended, or as amended by these Specifications. The seeding mixture shall be the Standard Roadside Mix (Canada No. 1 Lawn Grass Seed Mixture) as set out in OPSS 804. All cleanup and restoration work shall be performed to the full satisfaction of the Town Drainage Superintendent and/or Consulting Engineer.

When all of the work for this installation has been completed, the Contractor shall ensure that positive drainage is provided to all areas; and shall ensure that the site is left in a neat and workmanlike manner, all to the full satisfaction of the Town Drainage Superintendent and/or Consulting Engineer.

### **XIV. GENERAL CONDITIONS**

- a) The Town Drainage Superintendent and/or Consulting Engineer shall have authority to carry out minor changes to the work where such changes do not lessen the efficiency of the work.

- b) The Contractor shall satisfy itself as to the exact location, nature and extent of any existing structure, utility or other object which it may encounter during the course of the work. The Contractor shall indemnify and save harmless the Town of Essex and the Consulting Engineer and their representatives for any damages which it may cause or sustain during the progress of the work. It shall not hold the Town of Essex or the Consulting Engineer liable for any legal action arising out of any claims brought about by such damage caused by it.
- c) The Contractor shall provide a sufficient number of layout stakes and grade points so that the Drainage Superintendent and/or Consulting Engineer can review same and check that the work will generally conform to the design and project intent.
- d) The Contractor will be responsible for any damage caused by it to any portion of the Town road system, especially to the travelled portion. When excavation work is being carried out and the excavation equipment is placed on the travelled portion of the road, the travelled portion shall be protected by having the excavation equipment placed on satisfactory timber planks or timber pads. If any part of the travelled portion of the road is damaged by the Contractor, the Town shall have the right to have the necessary repair work done by its' employees and the cost of all labour and materials used to carry out the repair work shall be deducted from the Contractor's contract and credited to the Town. The Contractor, upon completing the works, shall clean all debris and junk, etcetera, from the roadside of the drain, and leave the site in a neat and workmanlike manner. The Contractor shall be responsible for keeping all public roadways utilized for hauling materials free and clear of mud and debris.
- e) The Contractor shall provide all necessary lights, signs, and barricades to protect the public. All work shall be carried out in accordance with the requirements of the Occupational Health and Safety Act, and latest amendments thereto. If traffic control is required on this project, signing is to comply with the M.T.O. Manual of Uniform Traffic Control Devices (M.U.T.C.D.) for Roadway Work Operations and Ontario Traffic Manual Book 7.
- f) During the course of the work the Contractor shall be required to connect existing drainage pipes to the Municipal Drain. In the event that polluted flows are discovered, the Contractor shall delay the connection of the pipe and leave the end exposed and alert the Town, the Drainage Superintendent and the Consulting Engineer so that steps can be taken by the Town to address the concern with the owner and the appropriate authorities. Where necessary the Contractor shall cooperate with the Town in providing temporary measures to divert the drain or safely barricade same. Should the connection be found acceptable by the authorities, the Contractor shall complete the connection of the drain as provided for in the specifications, at no extra cost to the project.
- g) Following the completion of the work, the Contractor is to trim up any broken or damaged limbs on trees which are to remain standing, and it shall dispose of said branches along with other brush, thus leaving the trees in a neat and tidy condition.

- h) The whole of the work shall be satisfactorily cleaned up, and during the course of the construction, no work shall be left in any untidy or incomplete state before subsequent portions are undertaken.
- i) During the course of the project the Contractor shall deal with any excess soil management from the project in accordance with Ontario Reg 406/19 pursuant to the Environmental Protection Act, R.S.O. 1990, c. E.19 and any subsequent amendments to same.
- j) All driveways, laneways and access bridges, or any other means of access on to the job site shall be fully restored to their former condition at the Contractor's expense. Before authorizing Final Payment, the Town Drainage Superintendent and the Consulting Engineer shall inspect the work in order to be sure that the proper restoration has been performed. In the event that the Contractor fails to satisfactorily clean up any portion of these accesses, the Consulting Engineer shall order such cleanup to be carried out by others and the cost of same be deducted from any monies owing to the Contractor.
- k) The Contractor will be required to submit to the Town, a Certificate of Good Standing from the Workplace Safety and Insurance Board prior to the commencement of the work and the Contractor will be required to submit to the Town, a Certificate of Clearance for the project from the Workplace Safety and Insurance Board before Final Payment is made to the Contractor.
- l) The Contractor shall furnish a Performance and Maintenance Bond along with a separate Labour and Material Payment Bond within ten (10) days after notification of the execution of the Agreement by the Town. One copy of said bonds shall be bound into each of the executed sets of the Contract. Each Performance and Maintenance Bond and Labour and Material Payment Bond shall be in the amount of 100% of the total Tender Price. All Bonds shall be executed under corporate seal by the Contractor and a surety company, authorized by law to carry out business in the Province of Ontario. The Bonds shall be acceptable to the Town in every way and shall guarantee faithful performance of the contract during the period of the contract, including the period of guaranteed maintenance which will be in effect for twelve (12) months after substantial completion of the works.

The Tenderer shall include the cost of bonds in the unit price of the Tender items as no additional payment will be made in this regard.

- m) The Contractor shall be required, as part of this Contract, to provide Comprehensive Liability Insurance coverage for not less than \$5,000,000.00 on this project; and shall name the Town of Essex and its' officials and the Consulting Engineer and their staff as additional insured under the policy. The Contractor must submit a copy of this policy to both the Town Clerk and the Consulting Engineer prior to the commencement of work.

- n) Monthly progress orders for payment shall be furnished the Contractor by the Town Drainage Superintendent. Said orders shall be for not more than 90% of the value of the work done and the materials furnished on the site. The paying of the full 90% does not imply that any portion of the work has been accepted. The remaining 10% will be paid 60 days after the final acceptance and completion of the work and payment shall not be authorized until the Contractor provides the following:
- i) A Certificate of Clearance for the project from the Workplace Safety and Insurance Board
  - ii) Proof of advertising
  - iii) A Statutory Declaration, in a form satisfactory to the Engineer and the Town, that all liabilities incurred by the Contractor and its Sub-Contractors in carrying out the Contract have been discharged and that all liens in respect of the Contract and Sub-Contracts thereunder have expired or have been satisfied, discharged or provided for by payment into Court.

The Contractor shall satisfy the Consulting Engineer or Town that there are no liens or claims against the work and that all of the requirements as per the Construction Act, 2018 and its' subsequent amendments have been adhered to by the Contractor.

- o) In the event that the Specifications, Information to Tenderers, or the Form of Agreement do not apply to a specific condition or circumstance with respect to this project, the applicable section or sections from the Canadian Construction Documents Committee C.C.D.C.2 shall govern and be used to establish the requirements of the work.
- p) Should extra work be required by the Town Drainage Superintendent or Consulting Engineer, and it is done on a time and material basis, the actual cost of the work will be paid to the Contractor with a 15% markup on the total actual cost of labour, equipment and materials needed to complete the extra work.
- q) The Contractor shall provide shop drawings of the proposed wall for decorative precast concrete block headwalls for approval by the Drainage Superintendent or Engineer prior to construction.



## APPENDIX "REI-A"



**STANDARD E.R.C.A. AND D.F.O.**  
**MITIGATION REQUIREMENTS**

As part of its work, the Contractor will implement the following measures that will ensure that any potential adverse effects on fish and fish habitat will be mitigated:

1. As per standard requirements, work will not be conducted at times when flows in the drain are elevated due to local rain events, storms, or seasonal floods. Work will be done in the dry.
2. All disturbed soils on the drain banks and within the channel, including spoil, must be stabilized immediately upon completion of work. The restoration of the site must be completed to a like or better condition to what existed prior to the works. The spoil material must be hauled away and disposed of at a suitable site, or spread an appropriate distance from the top of the drain bank to ensure that it is not washed back into the drain.
3. To prevent sediment entry into the drain in the event of an unexpected rainfall, silt barriers and/or traps must be placed in the channel during the works and until the site has been stabilized. All sediment and erosion control measures are to be in accordance with the related Ontario Provincial Standards. It is incumbent on the proponent and Contractors to ensure that sediment and erosion control measures are functioning properly and maintained/upgraded as required.
4. Silt or sand accumulated in the barrier traps must be removed and stabilized on land once the site is stabilized.
5. All activities including maintenance procedures should be controlled to prevent the entry of petroleum products, debris, rubble, concrete, or other deleterious substances into the water. Vehicular refuelling and maintenance should be conducted away from the water.
6. Any drain banks trimmed outside of the July 1st to September 15th timing window will require bio-degradable erosion control blankets to be installed to promote re-vegetation and to protect the slope from erosion in the interim.



# Measures to Avoid Causing Harm to Fish and Fish Habitat

If you are conducting a project near water, it is your responsibility to ensure you avoid causing [serious harm to fish](#) in compliance with the *Fisheries Act*. The following advice will help you avoid causing harm and comply with the *Act*.

**PLEASE NOTE:** This advice applies to all project types and replaces all “Operational Statements” previously produced by DFO for different project types in all regions.

## Measures

- Time work in water to respect [timing windows](#) to protect fish, including their eggs, juveniles, spawning adults and/or the organisms upon which they feed.
- Minimize duration of in-water work.
- Conduct instream work during periods of low flow, or at low tide, to further reduce the risk to fish and their habitat or to allow work in water to be isolated from flows.
- Schedule work to avoid wet, windy and rainy periods that may increase erosion and sedimentation.
  
- Design and plan activities and works in waterbody such that loss or disturbance to aquatic habitat is minimized and sensitive spawning habitats are avoided.
- Design and construct approaches to the waterbody such that they are perpendicular to the watercourse to minimize loss or disturbance to riparian vegetation.
- Avoid building structures on meander bends, braided streams, alluvial fans, active floodplains or any other area that is inherently unstable and may result in erosion and scouring of the stream bed or the built structures.
- Undertake all instream activities in isolation of open or flowing water to maintain the natural flow of water downstream and avoid introducing sediment into the watercourse.
  
- Plan activities near water such that materials such as paint, primers, blasting abrasives, rust solvents, degreasers, grout, or other chemicals do not enter the watercourse.
- Develop a response plan that is to be implemented immediately in the event of a sediment release or spill of a deleterious substance and keep an emergency spill kit on site.
- Ensure that building material used in a watercourse has been handled and treated in a manner to prevent the release or leaching of substances into the water that may be deleterious to fish.

- Develop and implement an Erosion and Sediment Control Plan for the site that minimizes risk of sedimentation of the waterbody during all phases of the project. Erosion and sediment control measures should be maintained until all disturbed ground has been permanently stabilized, suspended sediment has resettled to the bed of the waterbody or settling basin and runoff water is clear. The plan should, where applicable, include:
  - Installation of effective erosion and sediment control measures before starting work to prevent sediment from entering the water body.
  - Measures for managing water flowing onto the site, as well as water being pumped/diverted from the site such that sediment is filtered out prior to the water entering a waterbody. For example, pumping/diversion of water to a vegetated area, construction of a settling basin or other filtration system.
  - Site isolation measures (e.g., silt boom or silt curtain) for containing suspended sediment where in-water work is required (e.g., dredging, underwater cable installation).
  - Measures for containing and stabilizing waste material (e.g., dredging spoils, construction waste and materials, commercial logging waste, uprooted or cut aquatic plants, accumulated debris) above the high water mark of nearby waterbodies to prevent re-entry.
  - Regular inspection and maintenance of erosion and sediment control measures and structures during the course of construction.
  - Repairs to erosion and sediment control measures and structures if damage occurs.
  - Removal of non-biodegradable erosion and sediment control materials once site is stabilized.
- Clearing of riparian vegetation should be kept to a minimum: use existing trails, roads or cut lines wherever possible to avoid disturbance to the riparian vegetation and prevent soil compaction. When practicable, prune or top the vegetation instead of grubbing/uprooting.
- Minimize the removal of natural woody debris, rocks, sand or other materials from the banks, the shoreline or the bed of the waterbody below the ordinary high water mark. If material is removed from the waterbody, set it aside and return it to the original location once construction activities are completed.
- Immediately stabilize shoreline or banks disturbed by any activity associated with the project to prevent erosion and/or sedimentation, preferably through re-vegetation with native species suitable for the site.
- Restore bed and banks of the waterbody to their original contour and gradient; if the original gradient cannot be restored due to instability, a stable gradient that does not obstruct fish passage should be restored.
- If replacement rock reinforcement/armouring is required to stabilize eroding or exposed areas, then ensure that appropriately-sized, clean rock is used; and that rock is installed at a similar slope to maintain a uniform bank/shoreline and natural stream/shoreline alignment.
- Remove all construction materials from site upon project completion.

- Ensure that all in-water activities, or associated in-water structures, do not interfere with fish passage, constrict the channel width, or reduce flows.
- Retain a qualified environmental professional to ensure applicable permits for relocating fish are obtained and to capture any fish trapped within an isolated/enclosed area at the work site and safely relocate them to an appropriate location in the same waters. Fish may need to be relocated again, should flooding occur on the site.
- Screen any water intakes or outlet pipes to prevent entrainment or impingement of fish. Entrainment occurs when a fish is drawn into a water intake and cannot escape. Impingement occurs when an entrapped fish is held in contact with the intake screen and is unable to free itself.
  - In freshwater, follow these measures for design and installation of intake end of pipe fish screens to protect fish where water is extracted from fish-bearing waters:
    - Screens should be located in areas and depths of water with low concentrations of fish throughout the year.
    - Screens should be located away from natural or artificial structures that may attract fish that are migrating, spawning, or in rearing habitat.
    - The screen face should be oriented in the same direction as the flow.
    - Ensure openings in the guides and seals are less than the opening criteria to make “fish tight”.
    - Screens should be located a minimum of 300 mm (12 in.) above the bottom of the watercourse to prevent entrainment of sediment and aquatic organisms associated with the bottom area.
    - Structural support should be provided to the screen panels to prevent sagging and collapse of the screen.
    - Large cylindrical and box-type screens should have a manifold installed in them to ensure even water velocity distribution across the screen surface. The ends of the structure should be made out of solid materials and the end of the manifold capped.
    - Heavier cages or trash racks can be fabricated out of bar or grating to protect the finer fish screen, especially where there is debris loading (woody material, leaves, algae mats, etc.). A 150 mm (6 in.) spacing between bars is typical.
    - Provision should be made for the removal, inspection, and cleaning of screens.
    - Ensure regular maintenance and repair of cleaning apparatus, seals, and screens is carried out to prevent debris-fouling and impingement of fish.
    - Pumps should be shut down when fish screens are removed for inspection and cleaning.
- Avoid using explosives in or near water. Use of explosives in or near water produces shock waves that can damage a fish swim bladder and rupture internal organs. Blasting vibrations may also kill or damage fish eggs or larvae.
  - If explosives are required as part of a project (e.g., removal of structures such as piers, pilings, footings; removal of obstructions such as beaver dams; or preparation of a river or lake bottom for installation of a structure such as a dam or water intake), the potential for impacts to fish and fish habitat should be minimized by implementing the following measures:

- Time in-water work requiring the use of explosives to prevent disruption of vulnerable fish life stages, including eggs and larvae, by adhering to appropriate fisheries [timing windows](#).
- Isolate the work site to exclude fish from within the blast area by using bubble/air curtains (i.e., a column of bubbled water extending from the substrate to the water surface as generated by forcing large volumes of air through a perforated pipe/hose), cofferdams or aquadams.
- Remove any fish trapped within the isolated area and release unharmed beyond the blast area prior to initiating blasting
- Minimize blast charge weights used and subdivide each charge into a series of smaller charges in blast holes (i.e., decking) with a minimum 25 millisecond (1/1000 seconds) delay between charge detonations (see Figure 1).
- Back-fill blast holes (stemmed) with sand or gravel to grade or to streambed/water interface to confine the blast.
- Place blasting mats over top of holes to minimize scattering of blast debris around the area.
- Do not use ammonium nitrate based explosives in or near water due to the production of toxic by-products.
- Remove all blasting debris and other associated equipment/products from the blast area.

**Figure 1: Sample Blasting Arrangement**

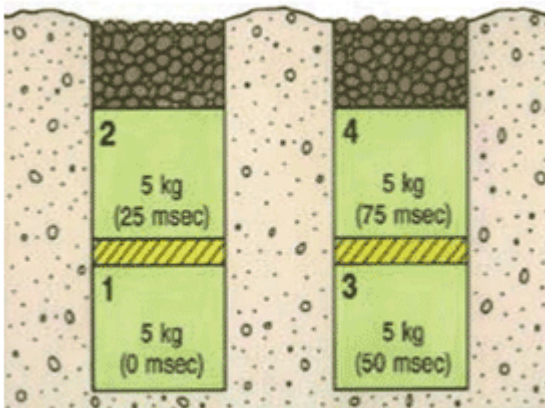

Per Fig. 1: 20 kg total weight of charge; 25 msecs delay between charges and blast holes; and decking of charges within holes.

- Ensure that machinery arrives on site in a clean condition and is maintained free of fluid leaks, invasive species and noxious weeds.

- Whenever possible, operate machinery on land above the high water mark, on ice, or from a floating barge in a manner that minimizes disturbance to the banks and bed of the waterbody.
- Limit machinery fording of the watercourse to a one-time event (i.e., over and back), and only if no alternative crossing method is available. If repeated crossings of the watercourse are required, construct a temporary crossing structure.
- Use temporary crossing structures or other practices to cross streams or waterbodies with steep and highly erodible (e.g., dominated by organic materials and silts) banks and beds. For fording equipment without a temporary crossing structure, use stream bank and bed protection methods (e.g., swamp mats, pads) if minor rutting is likely to occur during fording.
- Wash, refuel and service machinery and store fuel and other materials for the machinery in such a way as to prevent any deleterious substances from entering the water.

Date modified:  
2013-11-25



**SECTION II**

**SPECIFICATIONS**

**FOR FISH SALVAGE**

**GENERAL**  
**SECTION 201**

The Work shall include the capture, salvage and release of fish that are trapped or stranded as the result of the Contractor's operations, at locations identified in the Fish Salvage Plan, and in co-operation with the Essex Region Conservation Authority (E.R.C.A.).

Fish capture shall be performed prior to dewatering, and in such manner that will minimize the injury to the fish.

**MATERIALS**  
**SECTION 202**

All materials required for fish capture, salvage and release shall be supplied by the Contractor.

**CONSTRUCTION**  
**SECTION 203**

The Contractor shall not commence any fish capture, salvage and release work until the Fish Salvage Plan has been accepted by the Consultant and the Conservation Authority. All work shall be performed in accordance with the Fish Salvage Plan unless otherwise determined by the Consultant or the Conservation Authority.

The Contractor shall ensure an ice-free pool is maintained throughout all fish capture and release operations.

All fish shall be captured within the area specified and released at an acceptable location in the downstream water body. Fish shall be captured by electro fishing, netting, seining, trapping, or other method acceptable to the Consultant and/or the Conservation Authority.

**MEASUREMENT AND PAYMENT**  
**SECTION 204**

Payment for this Work will be included in the price bid for drainage work components or made at the lump sum price bid for "Fish Capture and Release". The lump sum price will be considered full compensation for all labour, materials, equipment, tools, and incidentals necessary to complete the Work to the satisfaction of the Consultant.



## APPENDIX "REI-B"



**SCHEDULE C**  
**MITIGATION PLAN**

The Municipality shall undertake measures to minimize adverse effects on species at risk in accordance with the general conditions described in Part B and taxa-specific conditions described in Part C, and the monitoring and reporting requirements described in Part D of this Mitigation Plan.

**PART A. DEFINITIONS**

**1. Definitions:**

1.1. In this Schedule, the following words shall have the following meanings:

"DFO" means Fisheries and Oceans Canada;

"MNR" means the Aylmer District Office of the Ministry of Natural Resources;

"Contact" means to contact the MNR in accordance with the notification/contact schedule provided to the Municipality by the MNR Designated Representative from time to time;

"Holding Tub" means a large, light-coloured container fitted with a non-airtight latching lid approved by the MNR for the temporary storage of captured snakes, turtles, amphibians, birds or eggs;

"Interagency Notification Form" means the form issued by DFO, available at [www.dfo-mpo.gc.ca](http://www.dfo-mpo.gc.ca), which is required to be completed when a drain is being maintained or constructed;

"Monitoring and Reporting Form" means the document that must be completed by the Municipality in accordance with Part D to this Schedule and will be provided to the Municipality;

"Ontario Operational Statement" means one of the documents issued by DFO, available at [www.dfo-mpo.gc.ca](http://www.dfo-mpo.gc.ca), that sets out the conditions and measures to be incorporated into a project in order to avoid negative impacts to fish and fish habitat in Ontario, as modified from time to time;

"Process Charts" means the charts attached as Part E to this Schedule which describe the steps set out in this Mitigation Plan;

"Seasonal Timing Windows Chart" means the chart attached as Part G to this schedule which describes the Sensitive Periods applicable to each Taxonomic Group;

"Sensitive Area" means a geographic area in the Municipality where additional mitigation measures are required to be undertaken for one or more Taxonomic Groups;

"Sensitive Areas Map" means any one of the maps attached as Part F to this schedule which sets out the applicable Sensitive Areas;

"Sensitive Period" means a time of year set out in the Seasonal Timing Windows Chart during which taxa-specific mitigation measures are required to be undertaken for a Taxonomic Group because of ambient air/water temperatures, water-levels or important life-history stages;

"Taxonomic Group" means the distinct group comprising one or more Species based on their taxonomic relationship and common approaches to mitigating adverse effects (i.e., fish, mussels, turtles, snakes, amphibians, birds or plants); and

"Work Zone" means the geographic area in the Municipality where an Activity in respect of one of the Drainage Works is being conducted.

- 1.2. For greater certainty, any defined terms that are not defined in section 1.1 have the same meanings as in the Agreement.

## **PART B. GENERAL MEASURES TO MINIMIZE ADVERSE EFFECTS**

### **2. Process Charts**

- 2.1. The general steps set out in this Part B are visually described in the Process Charts (Part E).

### **3. Review of Documentation**

- 3.1. Prior to conducting any Activities in respect of the Drainage Works the Municipality shall determine if conditions apply to the place, time or manner in which the Municipality wishes to pursue them by reviewing:
  - (a) the Sensitive Areas Maps (Part F) to determine if the Work Zone for the proposed Activities will occur within a Sensitive Area;
  - (b) the DFO Reference Guide for Fish and Mussel Species at Risk Distribution Maps: A Referral Review Tool for Projects Affecting Aquatic Species at Risk;
  - (c) the Seasonal Timing Windows Chart (Part G) to determine if the proposed Activities will occur during a Sensitive Period for one or more of the Taxonomic Groups; and
  - (d) the Process Charts to determine if prior notification is required;
  - (e) the mitigation measures for each applicable Taxonomic Group in Part C to determine what additional site-specific mitigation measures, if any, are required.
- 3.2. The Municipality shall document the results of the review undertaken in accordance with section 3.1 using the Monitoring and Reporting Form.

### **4. Sensitive Areas Maps**

- 4.1. The Sensitive Areas Maps contain sensitive information about the distribution of species at risk, are provided for the sole purpose of informing this Agreement and are not to be copied or distributed for any other purposes or to any other party without the prior written authorization of the MNR Designated Representative.

### **5. Prior Notification to Seek Direction**

- 5.1. If, after completing the review of documents described in section 3.1, the Municipality determines that the proposed Activities will be undertaken:

- (a) in a place;
- (b) at a time; or
- (c) in a manner,

that requires prior notification in accordance with the Process Charts, the Municipality shall provide prior notification to the MNR in order for the MNR to determine if the Municipality must undertake additional site-specific or Species-specific mitigation

measures to minimize adverse effects on the Species and, if applicable, to identify such measures.

- 5.2. The prior notification under section 5.1 shall include a completed Interagency Notification Form:
- (a) in respect of maintenance/repair where the proposed Activities are being undertaken pursuant to subsection 3(18) or section 74 of the *Drainage Act*; or
  - (b) in respect of construction/improvement where the proposed Activities are being undertaken pursuant to section 77 or 78 of the *Drainage Act*.
- 5.3. Where an Activity is undertaken in accordance with section 124 of the *Drainage Act* and would otherwise have required prior notification under section 5.1, the Municipality shall Contact the MNR by email prior to the commencement of the Activity, and complete and submit the applicable Interagency Notification Form within one week of the Activity's completion, unless otherwise directed in writing by the MNR Designated Representative.

## **6. General Mitigation Measures**

- 6.1. Notwithstanding that prior notification or additional mitigation measures may be required in accordance with this schedule, in undertaking any Activity at any time in respect of the Drainage Works the Municipality shall:
- (a) undertake the mitigation measures for sediment control and for erosion control and bank stabilization set out in The Drain Primer (Cliff Evanitski 2008) published by DFO (ISBN 978-0-662-48027-3), unless otherwise authorized in writing by the MNR Designated Representative;
  - (b) use net free, 100% biodegradable erosion control blanket for all erosion control or bank stabilization done in conjunction with their Activities or, if authorized in writing by the MNR Designated Representative, alternative erosion control blankets that provide equal or greater protection to individual Species; and
  - (c) where applicable, follow the guidelines set out in the following Ontario Operational Statements:
    - (i) Beaver Dam Removal;
    - (ii) Bridge Maintenance;
    - (iii) Culvert Maintenance;
    - (iv) Isolated Pond Construction;
    - (v) Maintenance of Riparian Vegetation in Existing Right of Ways; and
    - (vi) Temporary Stream Crossing.

## **PART C. TAXA-SPECIFIC MEASURES TO MINIMIZE ADVERSE EFFECTS**

### **ADDITIONAL MITIGATION MEASURES FOR MUSSEL SPECIES**

#### **7. Activities undertaken in Sensitive Areas for Mussels**

- 7.1. Subject to section 7.2, where a proposed Activity will occur in a Sensitive Area for a mussel Species, the Municipality shall Contact the MNR to seek further direction.
- 7.2. Section 7.1 does not apply where the applicable Drainage Works are:
- (a) in a naturally dry condition;
  - (b) classified as a Class F drain in DFO's *Class Authorization System for the Maintenance of Agricultural Municipal Drains in Ontario* (ISBN 0-662-72748-7); or
  - (c) a closed drain.

### **ADDITIONAL MITIGATION MEASURES FOR TURTLE SPECIES**

#### **8. Training and Required On Site Materials for Turtles**

- 8.1. The Municipality will ensure any person:
- (a) involved in the capture, temporary holding, transfer and release of any turtle Species has received training in proper turtle handling procedures; and
  - (b) who undertakes an Activity has a minimum of two Holding Tubs and cotton sacks on site at all times.

#### **9. Activities undertaken in Sensitive Areas and Sensitive Periods for Turtles**

- 9.1. Subject to section 9.2, where a proposed Activity will occur in a Sensitive Area for any turtle Species and during a Sensitive Period for that Species, the Municipality shall:
- (a) not undertake any Activities that include the excavation of sediment or disturbance to banks during the applicable Sensitive Period unless otherwise authorized;
  - (b) undertake Activities in accordance with any additional site-specific measures provided in writing by the MNR Designated Representative;
  - (c) avoid draw-down and de-watering of the Sensitive Area during the applicable Sensitive Period; and
  - (d) if authorized by the MNR Designated Representative under (a) above to undertake Activities that include excavation of sediment or disturbance of banks, in addition to any other measures required under (b) above, ensure any person undertaking an Activity has at least two Holding Tubs on site at all times.
- 9.2. Section 9.1 does not apply where the applicable Drainage Works are:
- (a) in a naturally dry condition;
  - (b) classified as a Class F drain in DFO's *Class Authorization System for the Maintenance of Agricultural Municipal Drains in Ontario* (ISBN 0-662-72748-7); or
  - (c) a closed drain.

## **10. Measures for Encounters with Turtles During a Sensitive Period**

- 10.1. Where one or more individuals belonging to a turtle Species is encountered in the undertaking of an Activity in any part of a Work Zone (including, but not limited to, a Sensitive Area) during a Sensitive Period for that Species, the Municipality shall:
- (a) capture and transfer all uninjured individuals of that Species into a Holding Tub;
  - (b) capture and transfer all individuals injured as a result of the Activities into a Holding Tub separate from any Holding Tub containing uninjured individuals;
  - (c) ensure that the Holding Tubs with the captured individuals are stored at a cool temperature to prevent freezing until the individuals can be transferred; and
  - (d) immediately Contact the MNR to seek direction and to arrange for the transfer of the individual turtles.

## **11. Measures for Encounters with Turtles Laying Eggs or Nest Sites**

- 11.1. Where one or more individuals belonging to a turtle Species laying eggs, or an active nest site of any turtle Species, is encountered in undertaking an Activity in a Work Zone, the Municipality shall:
- (a) not disturb a turtle encountered laying eggs and not conduct any Activities within 20 metres of the turtle while it is laying eggs;
  - (b) collect any displaced or damaged eggs and capture any injured dispersing juveniles and transfer them to a Holding Tub;
  - (c) store all captured injured individuals and collected eggs out of direct sunlight;
  - (d) immediately Contact the MNR to seek direction and to arrange for the transfer of any injured individuals and eggs;
  - (e) immediately stop any disturbance to the nest site and recover exposed portions with soil or organic material to protect the integrity of the remaining individuals;
  - (f) not drive any equipment over the nest site or conduct any Activities within 5 metres of the nest site;
  - (g) not place any dredged materials removed from the Drainage Works on top of the nest site;
  - (h) mark out the physical location of the nest site for the duration of the project but not by any means that might increase the susceptibility of the nest to predation or poaching; and
  - (i) where there are no collected eggs or captured individuals, record relevant information and Contact the MNR within 72 hours to provide information on the location of the nest site.

## **12. Measures for Encounters with Turtles Outside of a Sensitive Period**

- 12.1. Where one or more individuals belonging to a turtle Species is encountered while undertaking an Activity in any part of a Work Zone (including, but not limited to, a Sensitive Area) but outside of any Sensitive Period for that Species, the Municipality shall:
- (a) briefly stop the Activity for a reasonable period of time to allow any uninjured individual turtles of that Species to leave the Work Zone;

- (b) where individuals do not leave the Work Zone after the Activity is briefly stopped in accordance with (a) above, capture all uninjured individuals and release them in accordance with section 13.1;
- (c) where circumstances do not allow for their immediate release, transfer captured uninjured individuals for a maximum of 24 hours into a Holding Tub which shall be stored out of direct sunlight and then release them in accordance with section 13.1;
- (d) capture and transfer any individuals that have been injured into a Holding Tub separate from any Holding Tub containing uninjured individuals; and
- (e) store all captured injured individuals out of direct sunlight and immediately Contact the MNR to seek direction and to arrange for their transfer.

**13. Release of Captured Individuals Outside of a Sensitive Period**

- 13.1. Where uninjured individuals are captured under section 12.1, they shall be released:
- (a) within 24 hours of capture;
  - (b) in an area immediately adjacent to the Drainage Works;
  - (c) in an area that will not be further impacted by the undertaking of any Activity; and
  - (d) not more than 250 metres from the capture site.
- 13.2. Following a release under section 13.1, the Municipality shall Contact the MNR within 72 hours of the release to provide information on the name of the Drainage Works, the location of the encounter and the location of the release site.

**14. Measures for Dead Turtles**

- 14.1. Where one or more individuals of a turtle Species is killed as a result of an Activity in a Work Zone, or if a person undertaking an Activity finds a deceased individual of a turtle Species within the Work Zone, the Municipality shall:
- (a) place any dead turtles in a Holding Tub outside of direct sunlight; and
  - (b) Contact the MNR within 72 hours to seek direction and to arrange for the transfer of the dead individuals.

**ADDITIONAL MITIGATION MEASURES FOR SNAKE SPECIES**

**15. Training and Required On Site Materials for Snakes**

- 15.1. The Municipality will ensure any person:
- (a) involved in the capture, temporary holding, transfer and release of any snake Species has received training in proper snake handling procedures; and
  - (b) who undertakes an Activity has a minimum of two Holding Tubs and cotton sacks on site at all times.

**16. Activities undertaken in Sensitive Areas and Sensitive Periods for Snakes**

- 16.1. Where a proposed Activity involves physical infrastructure (e.g., culverts, pump houses, etc.) and will occur in a Sensitive Area for any snake Species and during a *Sensitive Period – Hibernation* for that Species, the Municipality shall undertake the Activity outside of the Sensitive Period, unless otherwise authorized by and in accordance with any site-specific measures provided in writing by the MNR Designated Representative.

- 16.2. Where a proposed Activity will occur at or adjacent to a known hibernacula (as identified by the MNR) for any snake Species and during a *Sensitive Period – Staging* for that Species, the Municipality shall:
- (a) erect effective temporary snake barriers approved by the MNR that will not pose a risk of entanglement for snakes and that shall be secured so that individual snakes may not pass over or under the barrier or between any openings to enter or re-enter the Work Zone;
  - (b) inspect the temporary snake barriers daily during periods when snakes are active, capture any individuals incidentally encountered within the area bounded by the snake barrier and release the captured individuals in accordance with section 20.1; and
  - (c) remove the temporary snake barriers immediately upon completion of the Activity.
- 16.3. Where a proposed Activity that does not involve physical infrastructure will occur in a Sensitive Area for any snake Species and during a *Sensitive Period – Staging* for that Species, the Municipality shall undertake the Activity outside of the Sensitive Period, unless otherwise authorized by and in accordance with any site-specific measures provided in writing by the MNR Designated Representative.

**17. Measures for Encounters with Snakes During a Sensitive Period**

- 17.1. Where one or more individuals belonging to a snake Species is encountered, or should an active hibernacula be uncovered, while conducting an Activity in any part of a Work Zone (including, but not limited to, a Sensitive Area) during a Sensitive Period for that Species, the Municipality shall:
- (a) capture and transfer all injured and uninjured individual snakes of that Species into individual light-coloured, drawstring cotton sacks;
  - (b) place all cotton sacks filled with the captured individuals into a Holding Tub;
  - (c) ensure that the Holding Tub with the captured individuals is stored at a cool temperature to protect the snakes from freezing until the individuals can be retrieved or transferred;
  - (d) if an active hibernacula is uncovered, cease all Activities at the hibernacula site; and
  - (e) immediately Contact the MNR to seek direction and to arrange for the transfer and/or retrieval.

**18. Measures for Encounters with Snake Nests**

- 18.1. Where an active nest of any of the snake Species is encountered and disturbed while undertaking an Activity in any part of a Work Zone, the Municipality shall:
- (a) collect any displaced or damaged eggs and transfer them to a Holding Tub;
  - (b) capture and transfer all injured dispersing juveniles of that Species into a light-coloured drawstring cotton sack;
  - (c) place all cotton sacks with the captured injured individuals into a Holding Tub;
  - (d) ensure that the Holding Tub with the captured injured individuals is stored out of direct sunlight;
  - (e) immediately Contact the MNR to seek direction and to arrange for the transfer of the injured individuals;
  - (f) immediately stop any disturbance to the nest site and loosely cover exposed portions with soil or organic material to protect the integrity of the remaining individuals;

- (g) not drive any equipment over the nest site or conduct any Activities within 5 metres of the nest site;
- (h) not place any dredged materials removed from the Drainage Works on top of the nest site;
- (i) mark out the physical location of the nest site but not by any means that might increase the susceptibility of the nest to predation or poaching; and
- (j) where there are no collected eggs or captured individuals, Contact the MNR within 72 hours to provide information on the location of the nest site.

#### **19. Measures for Encounters with Snakes Outside of a Sensitive Period**

- 19.1. Where one or more individuals belonging to a snake Species is encountered while undertaking an Activity in any part of a Work Zone (including, but not limited to, a Sensitive Area) but outside of any Sensitive Period for that Species, the Municipality shall:
- (a) follow the requirements in section 15;
  - (b) briefly stop the Activity for a reasonable period of time to allow any uninjured individual snakes of that Species to leave the Work Zone;
  - (c) if the individuals do not leave the Work Zone after the Activity is briefly stopped in accordance with (b) above, capture all uninjured individuals and release them in accordance with section 20.1;
  - (d) where circumstances do not allow for the immediate release of captured uninjured individuals, they may be transferred into individual, light-coloured, drawstring cotton sacks before placing them in a Holding Tub which shall be stored out of direct sunlight for a maximum of 24 hours before releasing them in accordance with section 20.1;
  - (e) capture and transfer any individuals injured as a result of conducting the Activities into a Holding Tub separate from any Holding Tub containing uninjured individuals; and
  - (f) store all captured injured individuals out of direct sunlight and immediately Contact the MNR to seek direction and to arrange for their transfer.

#### **20. Release of Captured Individuals Outside of a Sensitive Period**

- 20.1. Where uninjured individuals are captured under section 19.1, they shall be released:
- (a) within 24 hours of capture;
  - (b) in an area immediately adjacent to the Drainage Works where there is natural vegetation cover;
  - (c) in an area that will not be further impacted by the undertaking of any Activity; and
  - (d) not more than 250 metres from the capture site.
- 20.2. Following a release under section 20.1, the Municipality shall Contact the MNR within 72 hours of the release to provide information on the name of the Drainage Works, the location of the encounter and the location of the release site.

#### **21. Measures for Dead Snakes**

- 21.1. Where one or more individuals belonging to a snake Species is killed as a result of an Activity in a Work Zone, or if a person undertaking an Activity finds a deceased individual of a snake Species within the Work Zone, the Municipality shall:

- (a) collect and transfer any dead individuals into a Holding Tub outside of direct sunlight; and
- (b) Contact the MNR within 72 hours to seek direction and to arrange for the transfer of the carcasses of the dead individuals.

#### **ADDITIONAL MITIGATION MEASURES FOR HERBACEOUS PLANTS**

##### **22. Activities Undertaken in Sensitive Areas for Herbaceous Plants**

- 22.1. Where a proposed Activity will occur that involves physical disturbance to vegetated banks or the killing and/or removal of vegetation through chemical or mechanical means in a Sensitive Area for any herbaceous plant Species, the Municipality shall:
- (a) undertake the Activity outside of the Sensitive Period, unless otherwise authorized;
  - (b) limit equipment access and operations to the side of the Drainage Works that will minimize disturbances where any of the plant Species occur;
  - (c) locate temporary storage sites for excavated sediments or bank materials on areas of open soil away from where any of the plant Species are likely to occur;
  - (d) not use any broad spectrum herbicides in Sensitive Areas; and
  - (e) undertake Activities in accordance with any additional site-specific measures provided in writing by the MNR Designated Representative.

#### **ADDITIONAL MITIGATION MEASURES FOR TREE SPECIES**

##### **23. Additional Measures for Butternut**

- 23.1. Where Butternuts may exist in a Work Zone and may be affected by an Activity, the Municipality shall:
- (a) identify and mark as retainable trees all individual Butternut trees within the Work Zone during work planning site visits unless the individual Butternut has been assessed as a non-retainable tree due to infection by Butternut canker by a person designated by the Minister as a Butternut Health Assessor;
  - (b) retain and avoid disturbance to all individuals identified under (a) above that have been identified as retainable trees or that have not been assessed, unless otherwise authorized in writing by the MNR Designated Representative;
  - (c) conduct Activities by:
    - (i) limiting equipment access and operations to the side of the Drainage Works that will minimize disturbance to where any of the individual Butternut trees occur,
    - (ii) working around trees,
    - (iii) avoiding compacting and/or disturbing the soil by keeping excavation and other heavy equipment a minimum of 2 metres away from the main stem of retained individuals to avoid damaging roots and stems,
    - (iv) placing excavated materials on areas not within 2 metres of the main stem of retained individuals; and
    - (v) where branches are required to be removed to allow for safe operation of equipment, removing them using appropriate equipment, such as pruning saws, chain saws or lopping shears, in accordance with good forestry practices.

#### **24. Measures for Other Trees**

- 24.1. Where Kentucky Coffee-tree, Common Hoptree, Eastern Flowering Dogwood and American Chestnut may exist in a Work Zone and may be affected by an Activity, the Municipality shall:
- (a) identify and mark all individual Kentucky Coffee-tree, Common Hoptree, Eastern Flowering Dogwood and American Chestnut within the Work Zone during work planning site visits;
  - (b) avoid disturbance to all individuals identified under (a) above, unless otherwise authorized in writing by the MNR Designated Representative;
  - (c) conduct Activities by:
    - (i) limiting equipment access and operations to the side of the Drainage Works that will minimize disturbance where any of the individuals occur,
    - (ii) working around trees,
    - (iii) avoiding compacting and/or disturbing the soil by keeping excavation and other heavy equipment a minimum of 2 metres away from the main stem of retained individuals to avoid damaging roots and stems, and
    - (iv) placing excavated materials on areas not within 2 metres of the main stem of retained individuals; and
  - (d) where branches are required to be removed to allow for safe operation of equipment, remove them using appropriate equipment, such as pruning saws, chain saws or lopping shears, in accordance with good forestry practices.

#### **PART D. MONITORING AND REPORTING REQUIREMENTS**

##### **25. Compliance Monitoring.**

- 25.1. The Municipality shall inspect the undertaking of the Activities at the locations described in Part F of this Schedule C, and shall record the results of the inspections in the Monitoring and Reporting Form.
- 25.2. The Municipality shall record all encounters with Species and the resulting mitigation measures taken by the Municipality in the Monitoring and Reporting Form.

##### **26. Reporting**

- 26.1. Prior to March 31 of each year the Mitigation Plan is in effect, the Municipality shall submit a completed Monitoring and Reporting Form containing all of the information collected under sections 25.1 and 25.2 during the previous twelve months to the MNR Designated Representative.

##### **27. Review**

- 27.1. Within six months of the expiry of this Mitigation Plan but no later than three months from the time of its expiry, the Parties shall meet to review the measures and actions taken and the Activities undertaken during its term and to discuss the terms and conditions of the next Mitigation Plan.

## APPENDIX "REI-C"



# STANDARD SPECIFICATIONS FOR ACCESS BRIDGE CONSTRUCTION

## 1. PRECAST CONCRETE BLOCK & CONCRETE FILLED JUTE BAG HEADWALLS

After the Contractor has set the endwall foundations and the new pipe in place, it shall completely backfill same and install new precast concrete blocks or concrete filled jute bag headwalls at the locations and parameters indicated on the drawing. All concrete used for headwalls shall be a minimum of 30 mPa at 28 days and include 6% +/- 1% air entrainment.

Precast concrete blocks shall be interlocking and have a minimum size of 600mmX600mmX1200mm. Half blocks shall be used to offset vertical joints. Cap blocks shall be a minimum of 300mm thick. A foundation comprising minimum 300mm thick poured concrete or precast blocks the depth of the wall and the full bottom width of the drain plus 450mm embedment into each drain bank shall be provided and placed on a firm foundation as noted below. The Contractor shall provide a levelling course comprising a minimum thickness of 150mm Granular "A" compacted to 100% Standard Proctor Density or 20mm clear stone, or a lean concrete as the base for the foundation. The base shall be constructed level and flat to improve the speed of installation. Equipment shall be provided as required and recommended by the block supplier for placing the blocks such as a swift lift device for the blocks and a 75mm eye bolt to place the concrete caps,. The headwall shall extend a minimum of 150mm below the invert of the access bridge culvert with the top of the headwall set to match the finished driveway grade, unless a 150mm high curb is specified at the edge of the driveway. To achieve the required top elevation, the bottom course of blocks and footing may require additional embedment into the drain bottom. The Contractor shall provide shop drawings of the proposed wall for approval by the Drainage Superintendent or Engineer prior to construction.

Blocks shall be placed so that all vertical joints are staggered. Excavation voids on the ends of each block course shall be backfilled with 20mm clear stone to support the next course of blocks above. Walls that are more than 3 courses in height shall be battered a minimum of 1 unit horizontal for every 5 units of vertical height. The batter shall be achieved by careful grading of the footing and foundation base, or use of pre-battered base course blocks. Filter cloth as specified below shall be placed behind the blocks to prevent the migration of any fill material through the joints. Backfill material shall be granular as specified below. Where the wall height exceeds 1.8 metres in height, a uni-axial geogrid SG350 or equivalent shall be used to tie back the walls and be installed in accordance with the manufacturer's recommendations. The wall face shall not extend beyond the end of the access bridge pipe. Non-shrink grout shall be used to fill any gaps between the blocks and the access bridge pipe for the full depth of the wall. The grout face shall be finished to match the precast concrete block walls as closely as possible.

When constructing the concrete filled jute bag headwalls, the Contractor shall place the bags so that the completed headwall will have a slope inward from the bottom of the pipe to the top of the finished headwall. The slope of the headwall shall be one unit horizontal to five units vertical. The Contractor shall completely backfill behind the new concrete filled jute bag headwalls with Granular "B" and Granular "A" material as per O.P.S.S. Form 1010 and the granular material shall be compacted in place to a Standard Proctor Density of 100%. The placing of the jute bag headwalls and the backfilling shall be performed in lifts simultaneously. The granular backfill shall be placed and compacted in lifts not to exceed 305mm (12") in thickness.

The concrete filled jute bag headwalls shall be constructed by filling jute bags with concrete. All concrete used to fill the jute bags shall have a minimum compressive strength of 25 MPa in 28 days and shall be provided and placed only as a wet mix. Under no circumstance shall the concrete to be used for filling the jute bags be placed as a dry mix. The jute bags, before being filled with concrete, shall have a dimension of 460mm (18") x 660mm (26"). The jute bags shall be filled with concrete so that when they are laid flat, they will be approximately 100mm (4") thick, 305mm (12") to 380mm (15") wide and 460mm (18") long.

The concrete jute bag headwall to be provided at the end of the bridge pipe shall be a single or double bag wall construction as set out in the specifications. The concrete filled bags shall be laid so that the 460mm (18") dimension is parallel with the length of the new pipe. The concrete filled jute bags shall be laid on a footing of plain concrete being 460mm (18") wide, and extending for the full length of the wall, and 305mm (12") thick extending below the bottom of the culvert pipe.

All concrete used for the footing, cap and bags shall have a minimum compressive strength of 30 mPa at 28 days and shall include 6% ± 1% air entrainment.

Upon completion of the jute bag headwall the Contractor shall cap the top row of concrete filled bags with a layer of plain concrete, minimum 100mm (4") thick, and hand trowelled to obtain a pleasing appearance. If the cap is made more than 100mm thick, the Contractor shall provide two (2) continuous 15M reinforcing bars set at mid-depth and equally spaced in

the cap. The Contractor shall fill all voids between the concrete filled jute bags and the corrugated steel pipe with concrete, particular care being taken underneath the pipe haunches to fill all voids.

The completed jute bag headwalls shall be securely embedded into the drain bank a minimum of 450mm (18") measured perpendicular to the sideslopes of the drain.

As an alternate to constructing a concrete filled jute bag headwall, the Contractor may construct a grouted concrete rip rap headwall. The specifications for the installation of a concrete filled jute bag headwall shall be followed with the exception that broken pieces of concrete may be substituted for the jute bags. The concrete rip rap shall be approximately 460mm (18") square and 100mm (4") thick and shall have two (2) flat parallel sides. The concrete rip rap shall be fully mortared in place using a mixture composed of three (3) parts of clean sharp sand and one (1) part of Portland cement.

The complete placement and backfilling of the headwalls shall be performed to the full satisfaction of the Drainage Superintendent and the Engineer.

## **2. QUARRIED LIMESTONE ENDWALLS**

The backfill over the ends of the corrugated steel pipe shall be set on a slope of 1-½ units horizontal to 1 unit vertical from the bottom of the corrugated steel pipe to the top of each end slope and between the drain banks. The top 305mm (12") in thickness of the backfill over the ends of the corrugated steel pipe shall be quarried limestone. The quarried limestone shall also be placed on a slope of 1-½ units horizontal to 1 unit vertical from the bottom of the corrugated steel pipe to the top of each bank of the drain adjacent each end slope. The quarried limestone shall have a minimum dimension of 100mm (4") and a maximum dimension of 250mm (10"). The end slope protection shall be placed with the quarried limestone pieces carefully tamped into place with the use of a shovel bucket so that, when complete, the end protection shall be consistent, uniform, and tightly laid in place.

Prior to placing the quarried limestone end protection over the granular backfill and on the drain banks, the Contractor shall lay non-woven geotextile filter fabric "GMN160" conforming to O.P.S.S. 1860 Class I or approved equal. The geotextile filter fabric shall extend from the bottom of the corrugated steel pipe to the top of each end slope of the bridge and along both banks of the drain to a point opposite the ends of the pipe.

The Contractor shall take extreme care not to damage the geotextile filter fabric when placing the quarried limestone on top of the filter fabric.

## **3. BRIDGE BACKFILL**

After the corrugated steel pipe has been set in place, the Contractor shall backfill the pipe with Granular "B" material, O.P.S.S. Form 1010 with the exception of the top 305mm (12") of the backfill. The top 305mm (12") of the backfill for the full width of the excavated area (between each bank of the drain) and for the top width of the driveway, shall be Granular "A" material, O.P.S.S. Form 1010. The granular backfill shall be compacted in place to a Standard Proctor Density of 100% by means of mechanical compactors. All of the backfill material, equipment used, and method of compacting the backfill material shall be inspected and approved and meet with the full satisfaction of the Drainage Superintendent and Engineer.

## **4. GENERAL**

Prior to the work commencing, the Drainage Superintendent and Engineer must be notified, and under no circumstances shall work begin without one of them being at the site. Furthermore, the grade setting of the pipe must be checked, confirmed, and approved by the Drainage Superintendent or Engineer prior to continuing on with the bridge installation.

The alignment of the new bridge culvert pipe shall be in the centreline of the existing drain, and the placing of same must be performed totally in the dry.

Prior to the installation of the new access bridge culvert, the existing sediment build-up in the drain bottom must be excavated and completely removed. This must be done not only along the drain where the bridge culvert pipe is to be installed, but also for a distance of 3.05 metres (10 ft.) both upstream and downstream of said new access bridge culvert. When setting the new bridge culvert pipe in place it must be founded on a good undisturbed base. If unsound soil is encountered, it must be totally removed and replaced with 20mm (3/4") clear stone, satisfactorily compacted in place.

When doing the excavation work or any other portion of the work relative to the bridge installation, care should be taken not to interfere with, plug up, or damage any existing surface drains, swales, and lateral or main tile ends. Where damage is encountered, repairs to correct same must be performed immediately as part of the work.

The Contractor and/or landowner performing the bridge installation shall satisfy themselves as to the exact location, nature and extent of any existing structure, utility or other object that they may encounter during the course of the work. The Contractor shall indemnify and save harmless the Town, or the Municipality, the Engineer, and their staff from any damages which it may cause or sustain during the progress of the work. It shall not hold them liable for any legal action arising out of any claims brought about by such damage caused by it.

Where applicable, the Contractor and/or landowner constructing the new bridge shall be responsible for any damage caused by them to any portion of the Town road right-of-way. They shall take whatever precautions are necessary to cause a minimum of damage to same and must restore the roadway to its original condition upon completion of the works.

When working along a municipal roadway, the Contractor shall provide all necessary lights, signs, barricades and flagpersons as required to protect the public. All work shall be carried out in accordance with the requirements of the Occupational Health and Safety Act, and latest amendments thereto. If traffic control is required on this project, it is to comply with the M.T.O. Traffic Control Manual for Roadway Work Operations and Ontario Traffic Manual Book 7.

Once the bridge installation has been completed, the drain sideslopes directly adjacent the new headwalls and/or endwalls are to be completely restored including revegetation, where necessary.

All of the work required towards the installation of the bridge shall be performed in a neat and workmanlike manner. The general site shall be restored to its' original condition, and the general area shall be cleaned of all debris and junk, etc. caused by the work

All of the excavation, installation procedures, and parameters as above mentioned are to be carried out and performed to the full satisfaction of the Drainage Superintendent and Engineer.

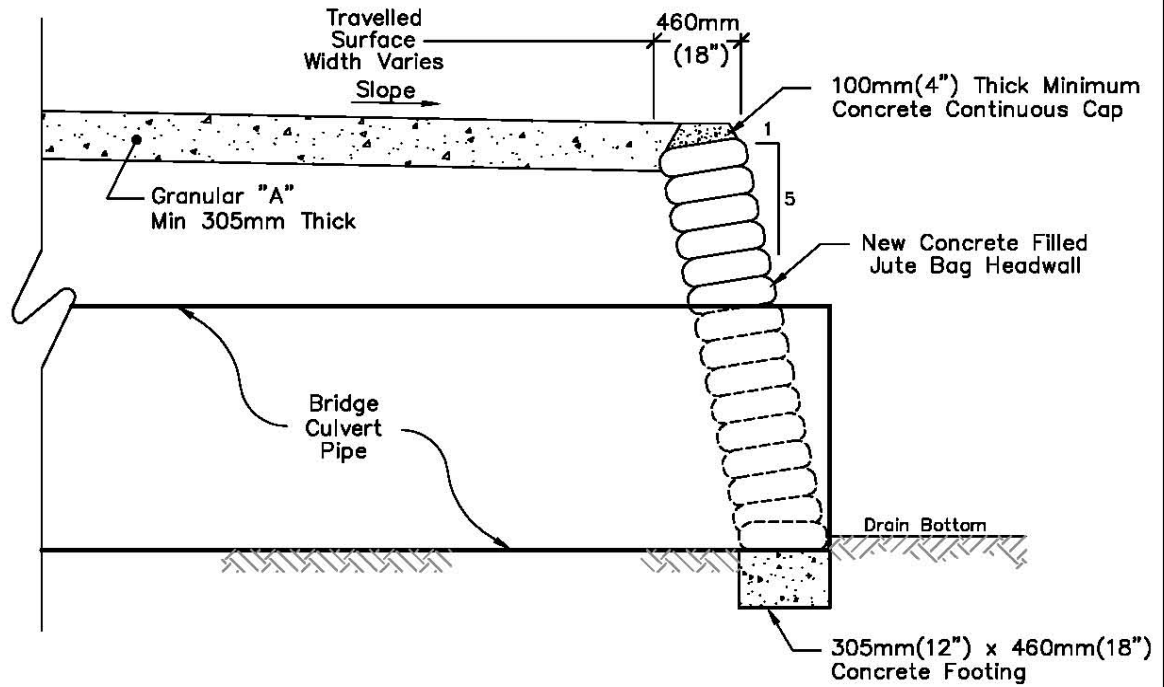

**Typical Jute Bag Headwall**

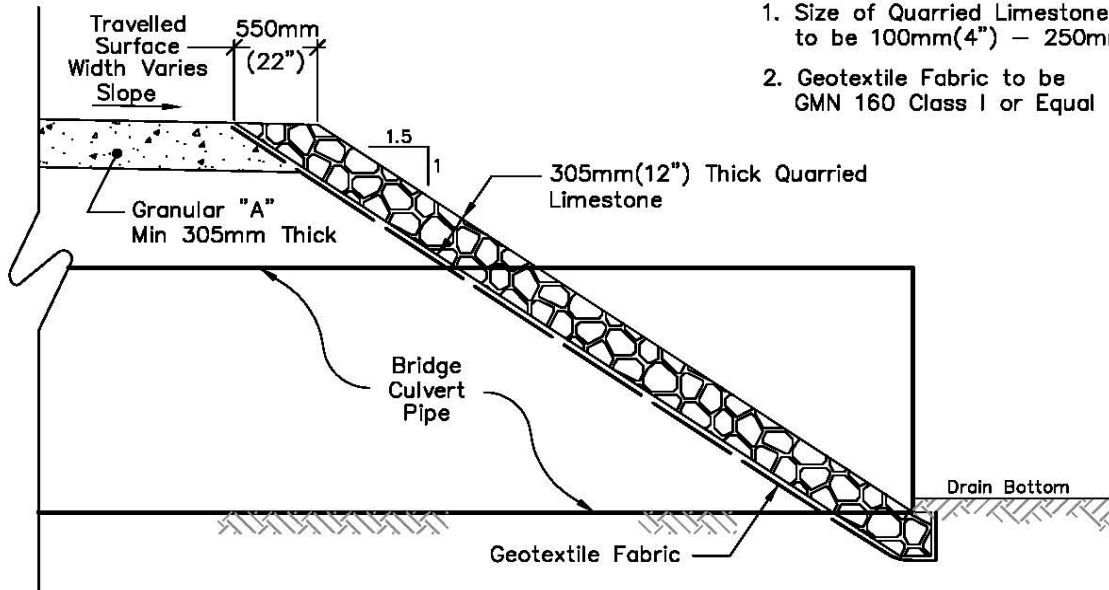

**NOTE:**

1. Size of Quarried Limestone to be 100mm(4") – 250mm(10")
2. Geotextile Fabric to be GMN 160 Class I or Equal

**Typical Quarried Limestone End Protection**

***Rood Engineering Inc.***

***Consulting Engineers***

***9 Nelson Street***

***Leamington, Ontario N8H 1G6***

***519-322-1621***

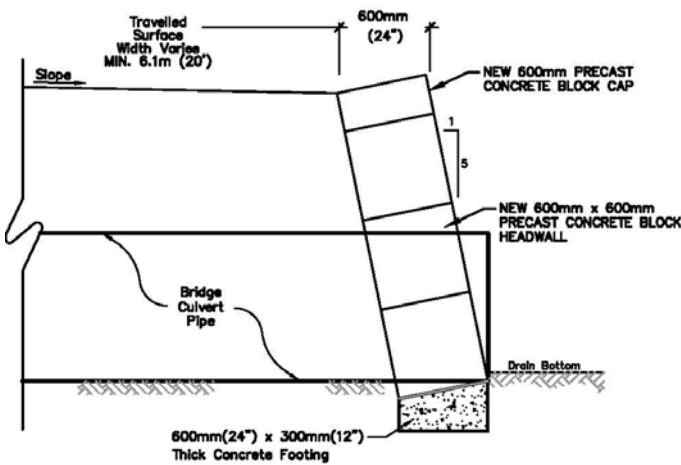
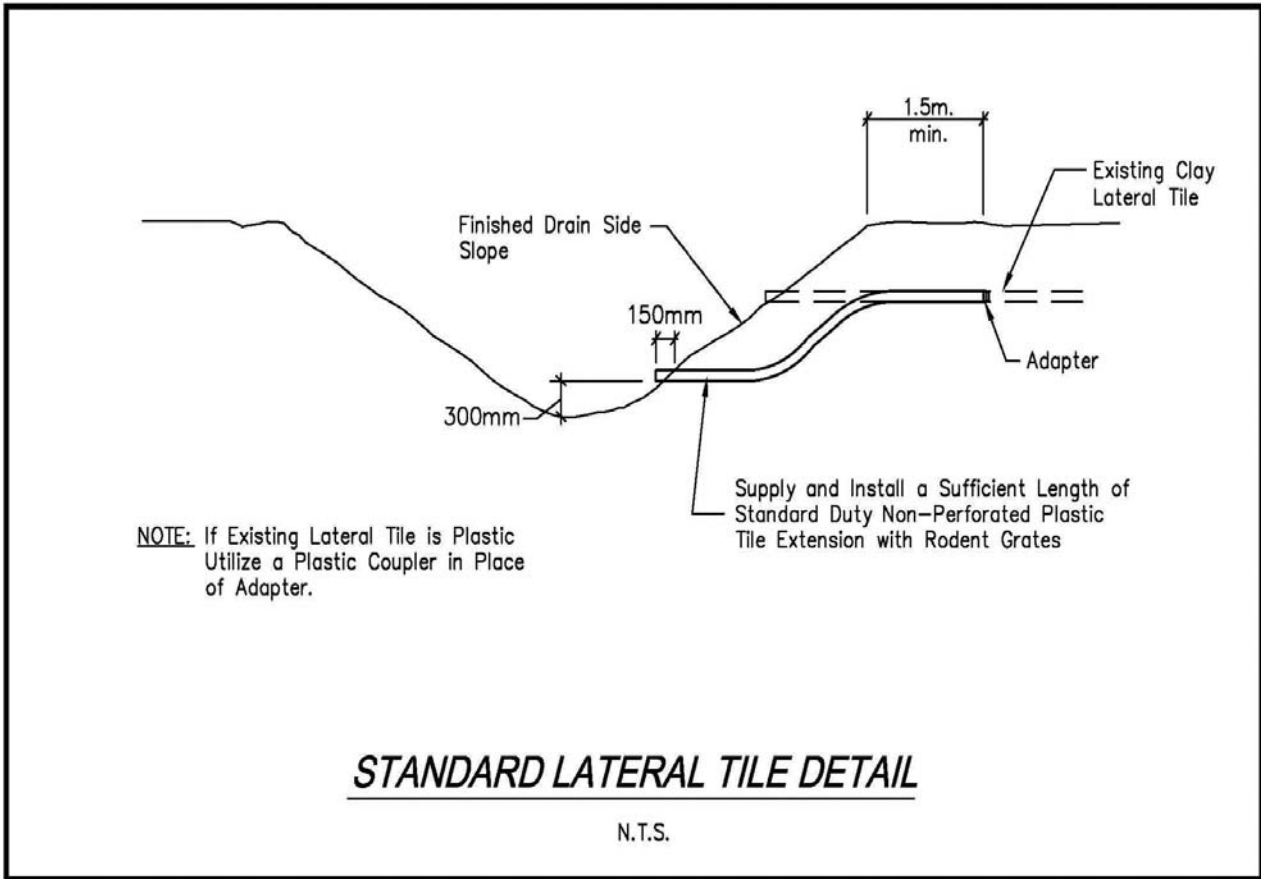

**TYPICAL PRECAST CONCRETE BLOCK END PROTECTION**  
Scale = N.T.S.

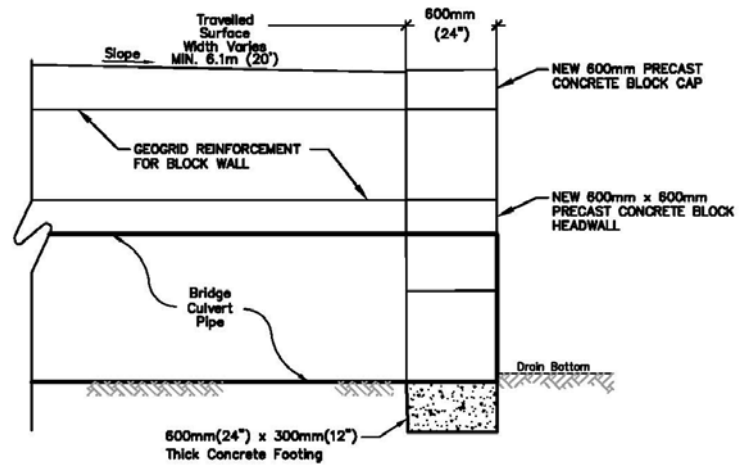

**TYPICAL VERTICAL PRECAST CONCRETE BLOCK END PROTECTION**  
Scale = N.T.S.



## APPENDIX "REI-D"



PLANS, PROFILE, CROSS-SECTIONS AND DETAILS

OF THE  
**REPLACEMENT BRIDGE**  
OVER THE  
**14TH CONCESSION WEST DRAIN**

IN THE  
(Geographic Township of Maidstone)  
IN THE  
**TOWN OF ESSEX**  
IN THE  
**COUNTY OF ESSEX • ONTARIO**

*Gerard Roed*  
GERARD ROED, P.ENG.

**ROOD**  
**ENGINEERING**  
**INC.**  
CONSULTING ENGINEERS  
Leamington, Ontario  
519-322-1621



DATE: May 8th, 2026

**TOWN OF ESSEX**  
MAYOR: SHERRY BONDY  
CLERK: JOE MALANDRUCCOLO  
DRAINAGE SUPERINTENDENT: LINDSAY DEAN

**BENCHMARKS:**

- TOP OF CENTER OF EAST HEADWALL OF EXISTING CONC. SPAN BRIDGE LOCATED AT STA. 1+285.53 ALONG THE 14TH CONCESSION WEST DRAIN.  
**ELEV. = 186.821m**
- TOP OF CENTER OF EAST CONCRETE FILLED CSP BOLLARD AS PART OF ERCA GREENWAY GATE LOCATED SOUTH OF 14TH CONCESSION ROAD  
**ELEV. = 186.712m**

**NOTE:**  
1. Size of Quarried Limestone to be 100mm(4") - 250mm(10")  
2. Geotextile Fabric to be GMN 160 O.P.S.S CLASS 1

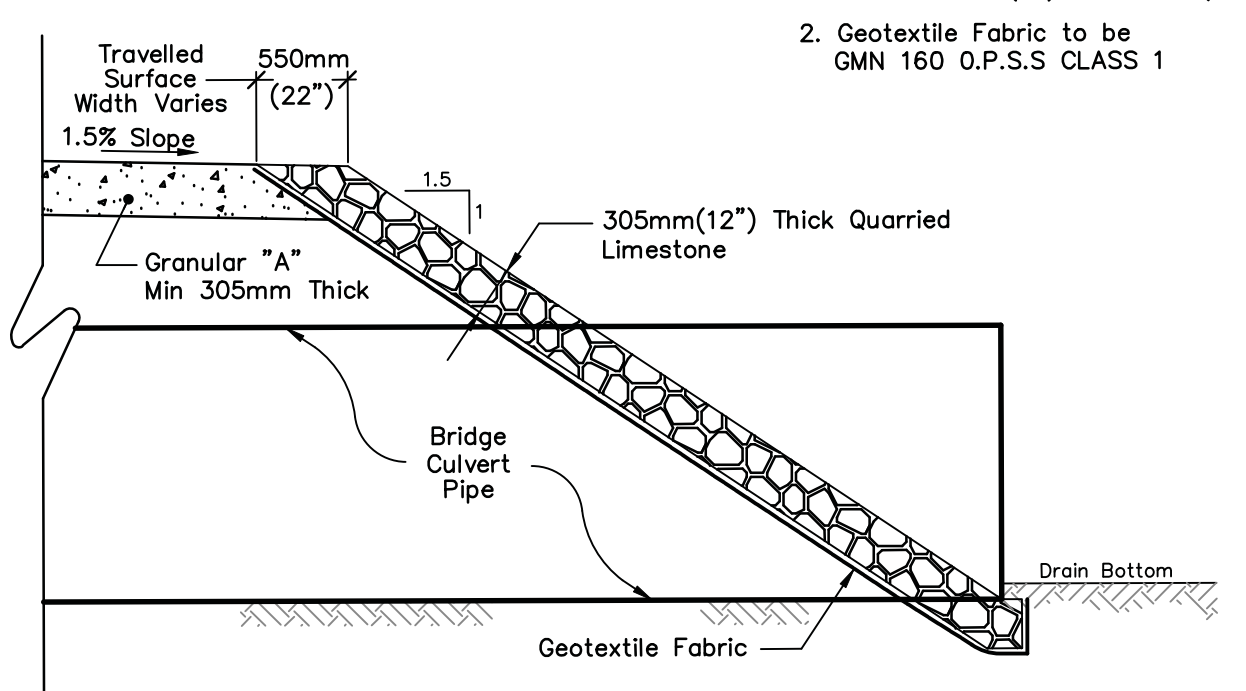

**TYPICAL QUARRIED LIMESTONE END PROTECTION**  
Scale = NTS

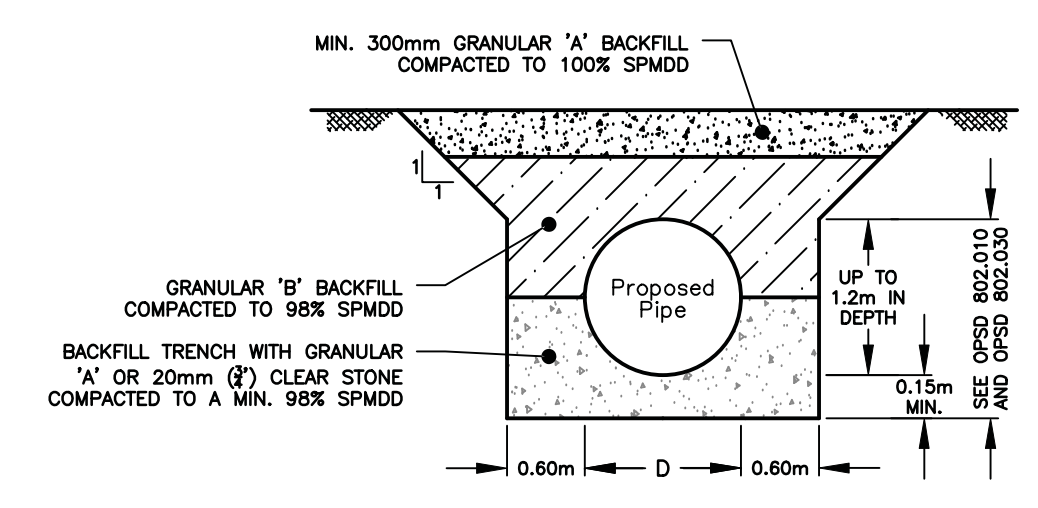

**TYPICAL CULVERT BACKFILL DETAIL**  
Scale = NTS

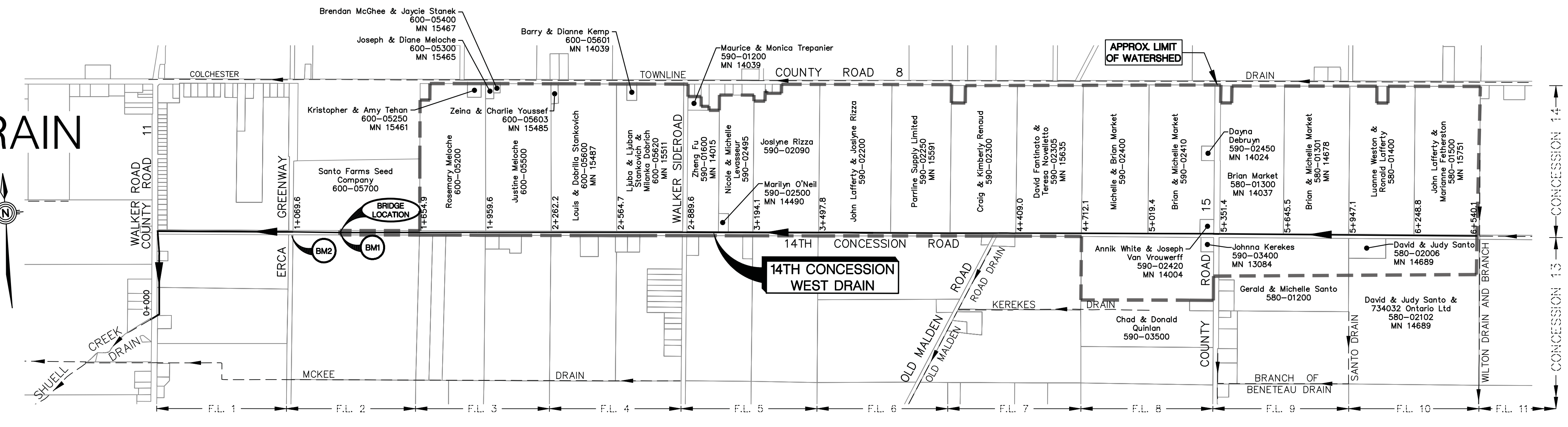

**WATERSHED PLAN**  
SCALE = 1:12,000

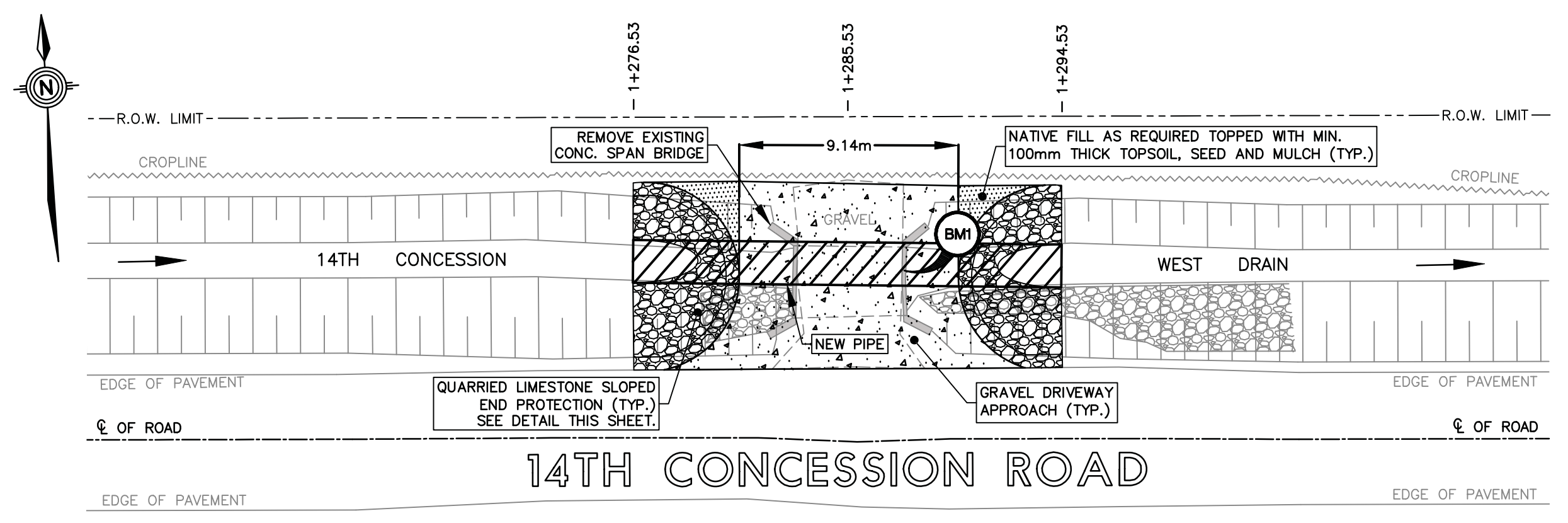

**BRIDGE PLAN**  
SCALE = 1:200

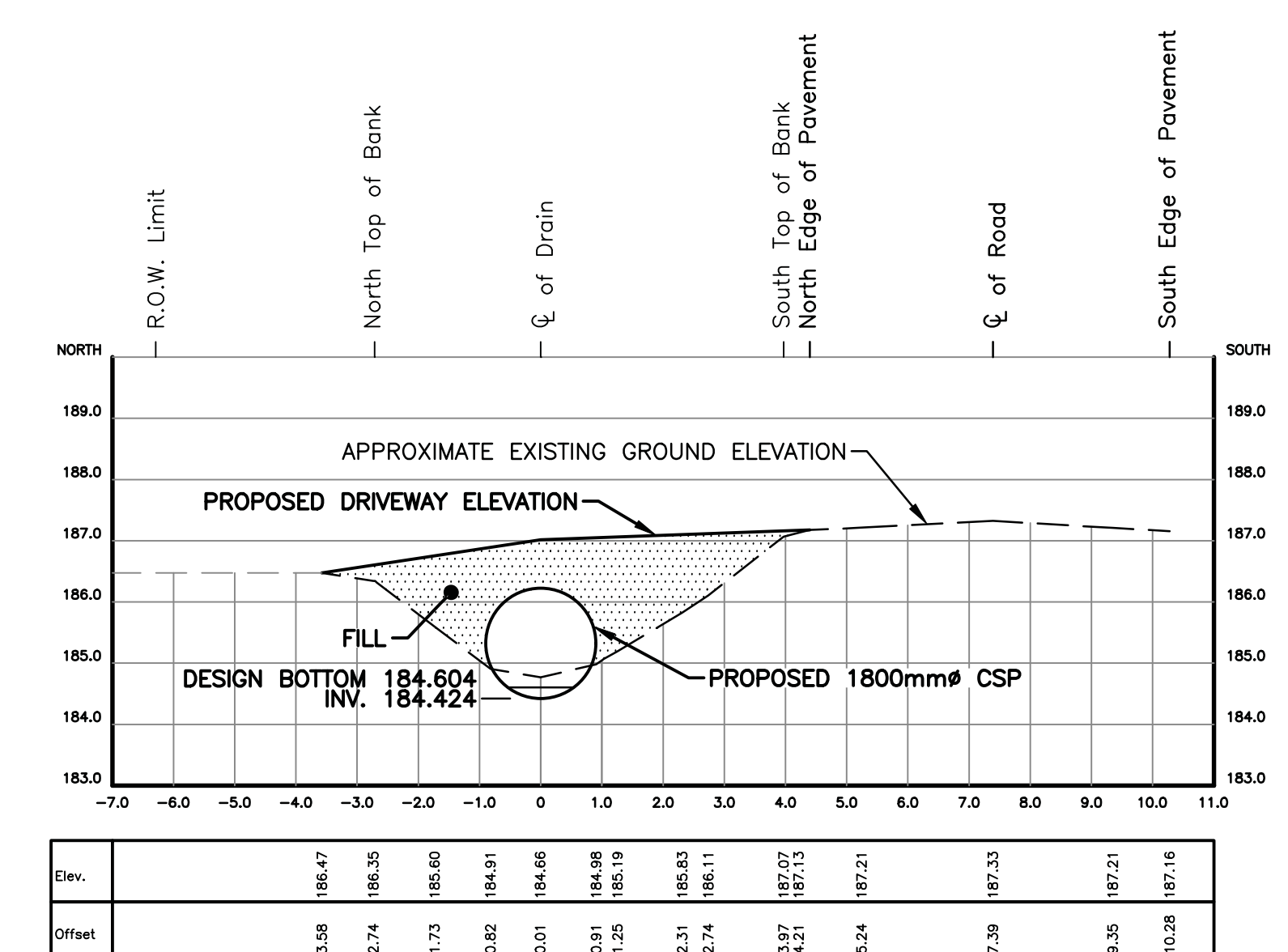

**STA 1+289.0**  
SCALE = 1:100

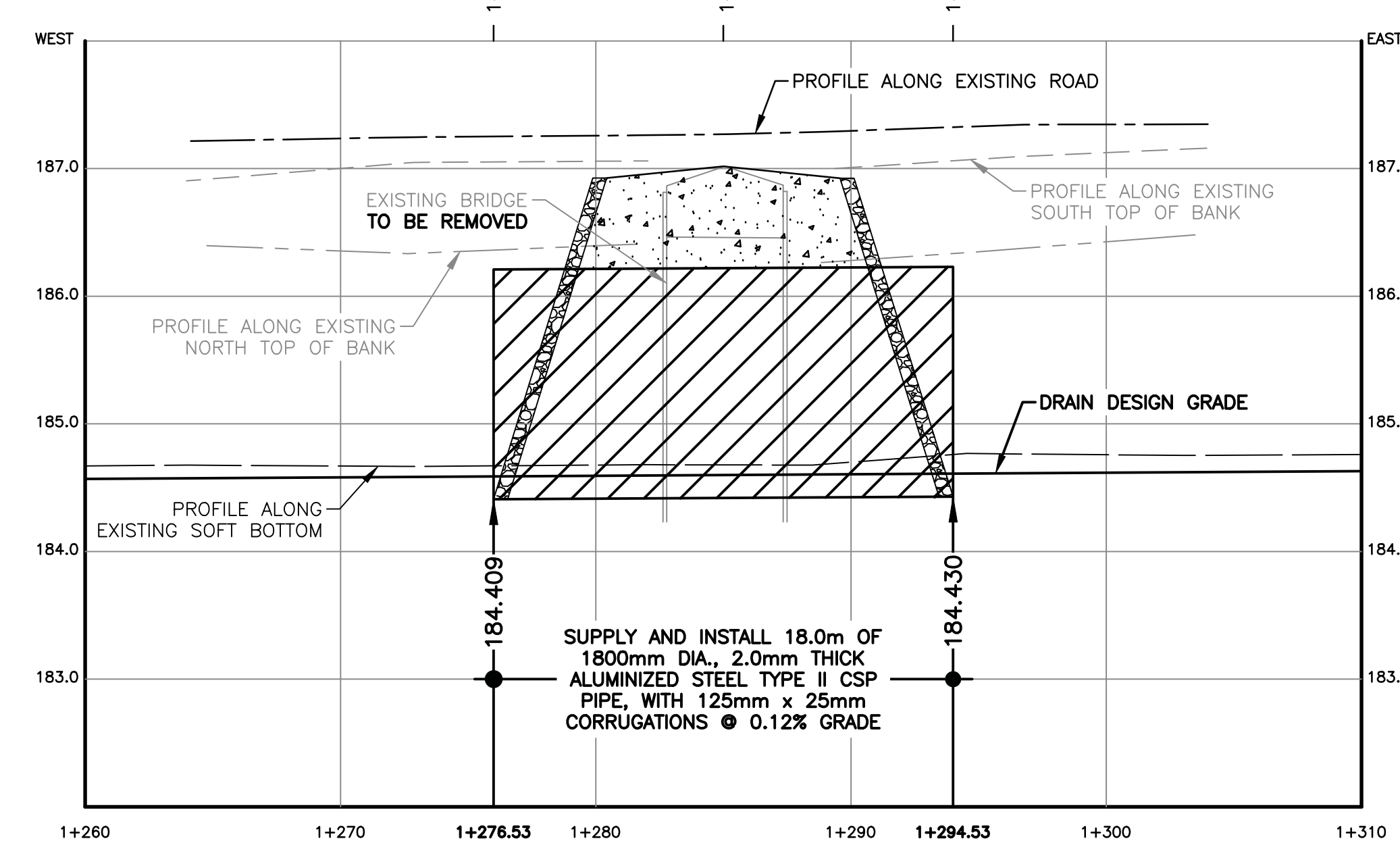

**BRIDGE PROFILE**  
SCALE = H 1:200  
V 1:40

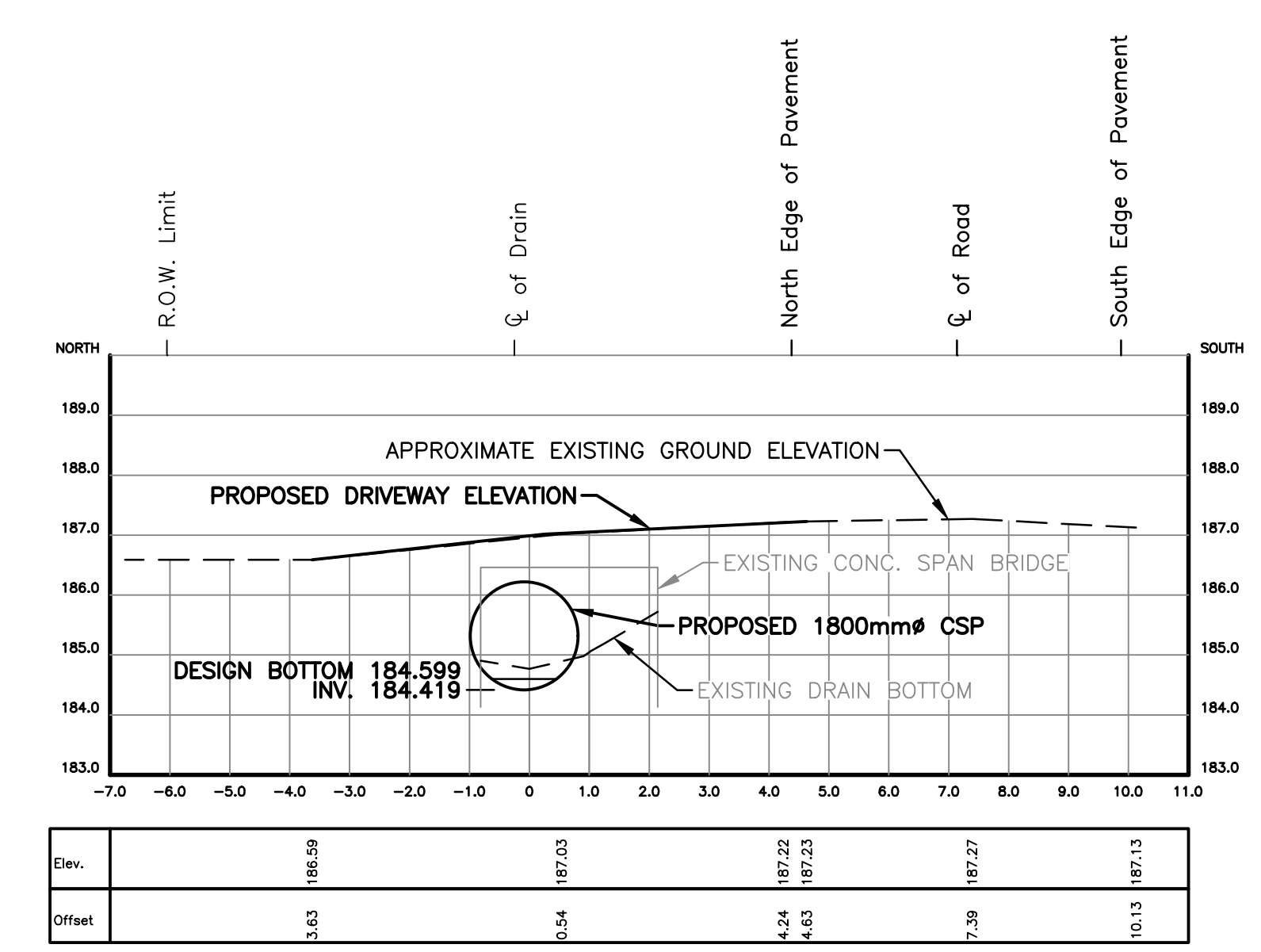

**STA 1+285.53 (CENTERLINE OF DRIVEWAY)**  
SCALE = 1:100