



Entrance Application

DATE: DD MM YYYY

****THIS IS NOT A PERMIT****

1. LOCATION

Street No.	Street Name
------------	-------------

Additional Location Information (ie. nearest intersection or lot number):

2. PROPOSED WORK (Check all that apply)

<input type="checkbox"/> Construct a new paved entrance Concrete	<input type="checkbox"/> Construct an agricultural access (if over municipal drain contact Drainage Department)
<input type="checkbox"/> Construct a new paved entrance Asphalt	<input type="checkbox"/> Change the design/location of entrance
<input type="checkbox"/> Repave an existing entrance Concrete	<input type="checkbox"/> Curb cut
<input type="checkbox"/> Repave an existing entrance Asphalt	<input type="checkbox"/> Plant tree(s)/landscaping
<input type="checkbox"/> Construct a temporary entrance	<input type="checkbox"/> Other:

3. DESCRIPTION OF WORK

Please describe work:		
Proposed dates of work:	From (dd-mm-yyyy)	To (dd-mm-yyyy)
Impact to road:	<input type="checkbox"/> Daily Closure	<input type="checkbox"/> Continuous Closure
	<input type="checkbox"/> Other:	

4. APPLICANT'S INFORMATION

Last Name		First Name	
Company Name (if applicable)			
Mailing Address			
Apt/Unit	City/Town	Province	Postal Code
Phone No. ()	Cell Phone No. ()	Email Address	

Application Checklist:

- Plan/drawings detailing location and extent of proposed works
- Applicable Permit Fee & Deposit (Cheque made payable to the Corporation of the Town of Essex)

Applicant Signature: _____ Date: _____

Conditions of Application

General:

1. This application is not a permit and does not give the applicant the authority to complete any works outlined within.
2. All works proposed under this application must be in conformance with current Town of Essex standards and requirements.
3. The site must be restored to the satisfaction of the Town of Essex.
4. In accordance with the *Ontario Underground Infrastructure Notification System Act*, excavators (including residents) are required to call for locates before digging. Please contact Ontario One Call before any excavation.
5. All changes and/or deviations from the submitted plans and/or locations shall be subject to re-approval by the Town of Essex.
6. Agricultural access to be constructed to OPSD 301.020
7. Positive drainage shall be maintained during the course of work.
8. All utilities' infrastructure shall be protected and supported, to the satisfaction of the affected utility, this includes water and sewer cleanouts. Damage to utilities will result in the retention of deposit until the utility is repaired. For questions, contact the Infrastructure Services Department at 519-776-7336 ext 1145
9. The Applicant shall not cut, trim or interfere with any trees (including roots) in the right-of-way without approval by the Town of Essex.
10. The Applicant agrees and accepts full responsibility to supply, maintain, clean and place all barricades, warning signs, delineators and flashing lights necessary for the protection of the public and the safe operation of the installation at the Applicant's own expense, and comply with all other applicable requirements of the Ontario Traffic Manual, Book 7, latest revision. (Note: This manual depicts minimum standards, additional signing may be required.)
11. All disturbed or affected areas will be maintained and restoration guaranteed for one year after complete acceptance of this work by the Town of Essex at the Applicant's expense.
12. Indemnity Deposits will only be released to the applicant described in Section 4 of this permit.
13. Indemnity Deposits will only be held for a five (5) year period from the date of issuance of this permit. After this five (5) year period the deposit is considered non-refundable and relinquished to the Town of Essex.

Inspections (REQUIRED):

1. Contact the Town of Essex Road Infrastructure Services Department at least 72 hours to arrange a site meeting for the layout of the driveway approach prior to cutting the concrete curb. Failure to schedule a pre-curb cut site inspection could result in the removal and remedy of the curb by the applicant and the forfeiture of the indemnity deposit.
2. Contact the Town of Essex infrastructure Services Department at least 72 hours prior to hard surfacing (Concrete or Asphalt) to arrange for "pre-pour" inspection. Failure to schedule a pre pour inspection could result in the removal and remedy of the driveway by the applicant and the forfeiture of the indemnity deposit.
3. For agricultural entrance permits contact the Town of Essex Infrastructure Department to verify inverts of new culverts prior to backfill.
4. Contact the Town of Essex Infrastructure Services Department at least 72 hours prior to pouring concrete or paving asphalt to arrange a site meeting to check for conformance to Town of Essex standards. The driveway should have been excavated, the granular base placed and compacted and any PDC services or water valves within the driveway approach brought to grade for a pre-pour/pave inspection. Failure to schedule a pre-pour site inspection could result in the removal and remedy of the driveway by the applicant and the forfeiture of the indemnity deposit.
5. Contact the Town of Essex Infrastructure Services Department following completion of the work (including final grading and grass) for final inspection and return of deposit(s).
6. Inspections can be scheduled by contacting Town of Essex - Infrastructure Services Department at 519-776-7336 ext. 1145

Indemnification:

The Applicant agrees to:

1. Accept full responsibility for the protection of all utilities' plant, private property and persons affected by its operations.
2. Indemnify and save harmless the Town of Essex from all actions, incorrectly or negligently performed by the Applicant as required by the terms of this permit or the Protection of Highways By-law, and will be responsible for damages, injuries, or accidents resulting from any of his/her operations, or caused by reason of construction, maintenance or existence of the work, or materials, plants, equipment used in connection with the works.

Failure to comply with all conditions will void this Application

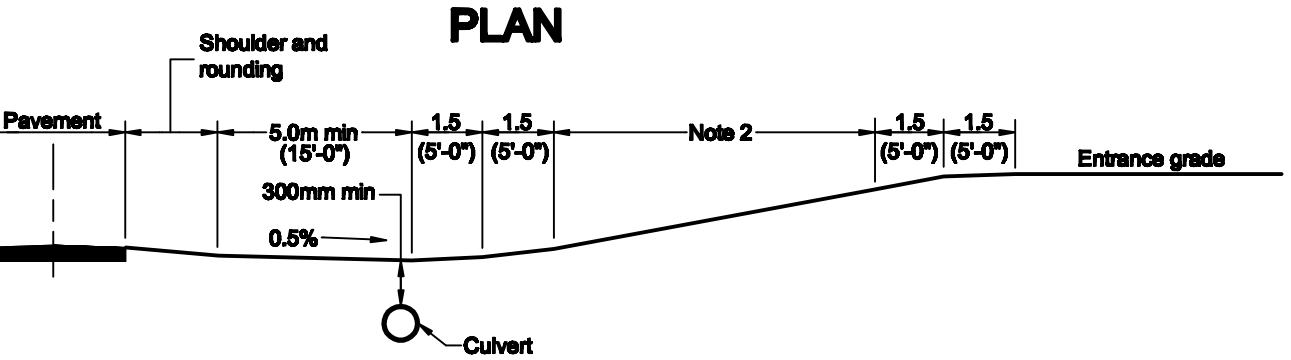
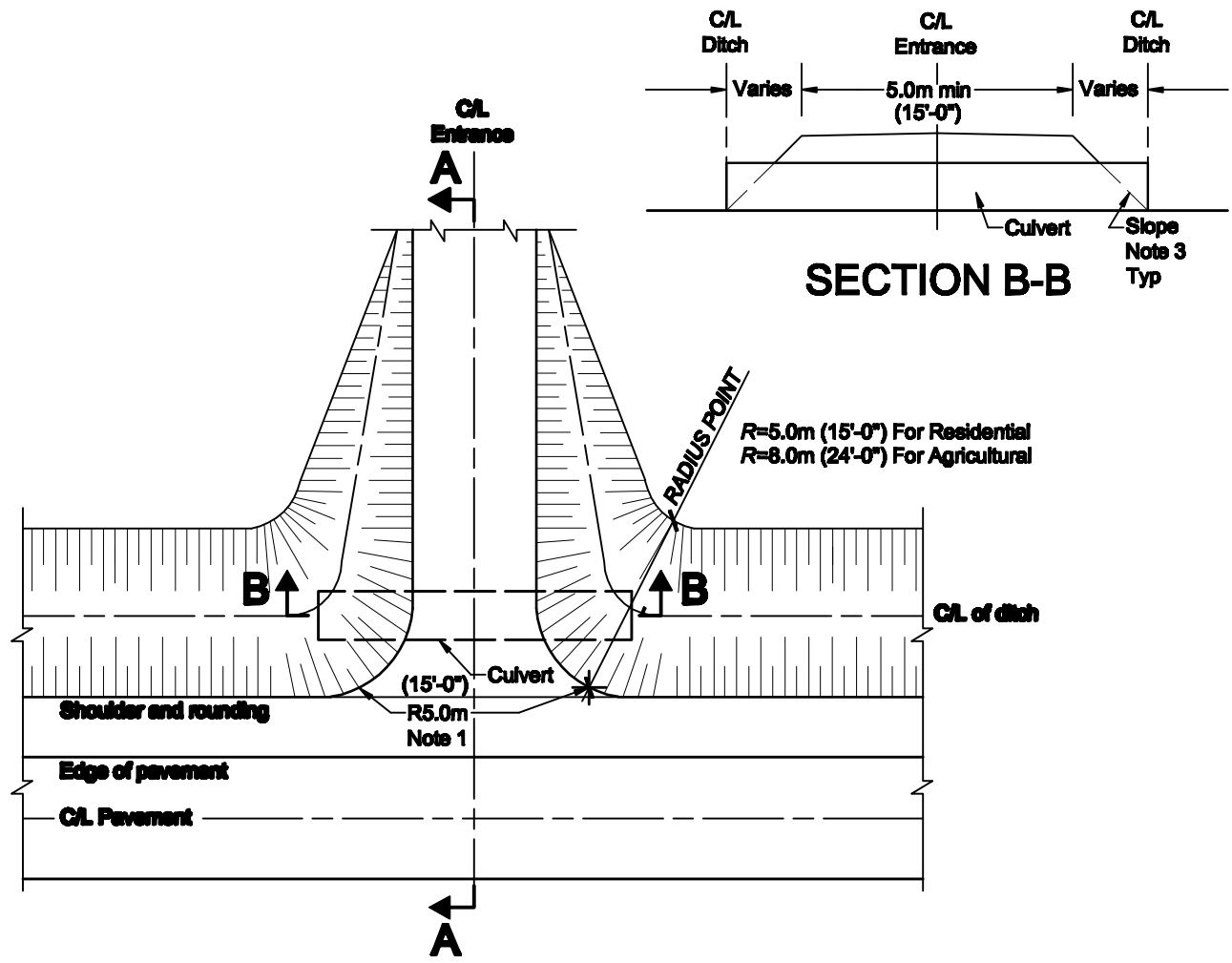

SECTION A-A

NOTES:

- 1 Radius shall be 8.0m when entrance is used for farm equipment.
- 2 Maximum gradient: 6% for residential entrances and 10% for farm and field entrances.
- 3 Slope shall be 3H:1V or flatter when specified.
- A All dimensions are in metres unless otherwise shown.

TOWN OF ESSEX
Drainage Department
Rural Entrances to Roads on Fill

Entrance
Detail 1



Date: August 6, 2013
 Drawn By: J.S.

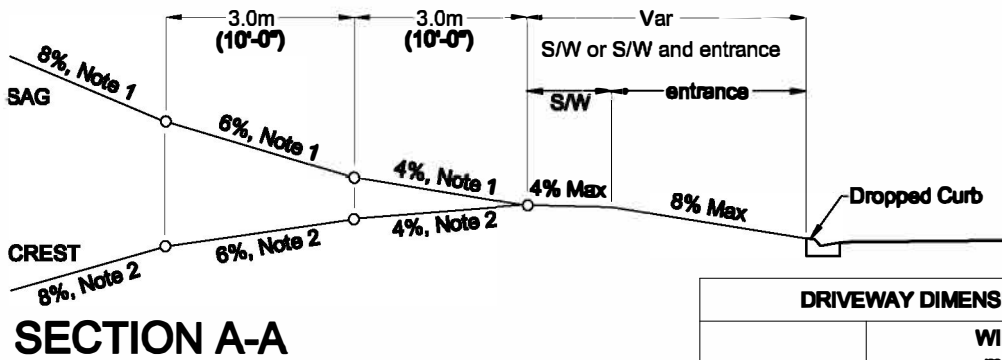
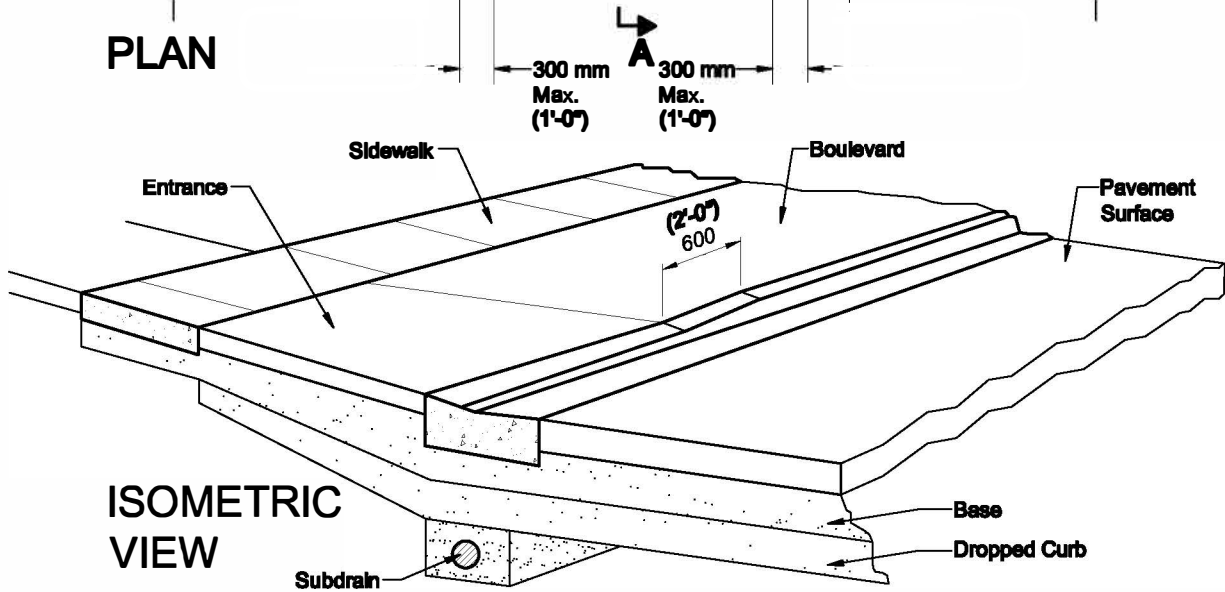
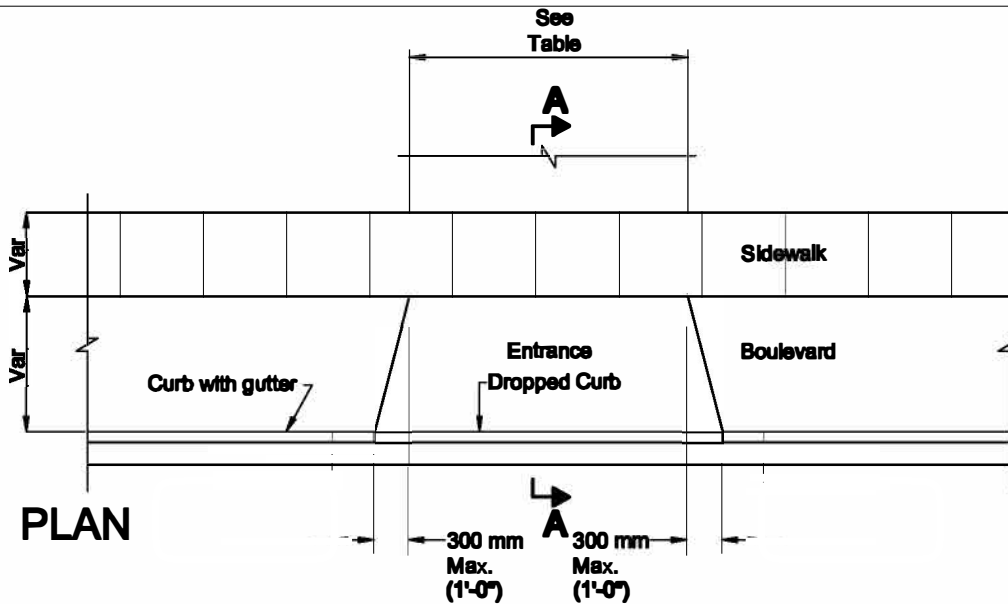

NOTES:

- 1 Maximum upgrade shall be 10%.
- 2 Maximum downgrade shall be 8%.
- A All dimensions are in millimetres unless otherwise shown.

DRIVEWAY DIMENSIONS				
LAND USE	WIDTH m (ft)			
	Single		Double	
	Min.	Max.	Min.	Max.
Residential	3.0	4.3	6.0	7.0
	(10'-0")	(14'-0")	(20'-0")	(23'-0")

TOWN OF ESSEX
Drainage Department

Urban Residential Entrance

Entrance
Detail 2



Date: August 6, 2013
Drawn By: J.S.

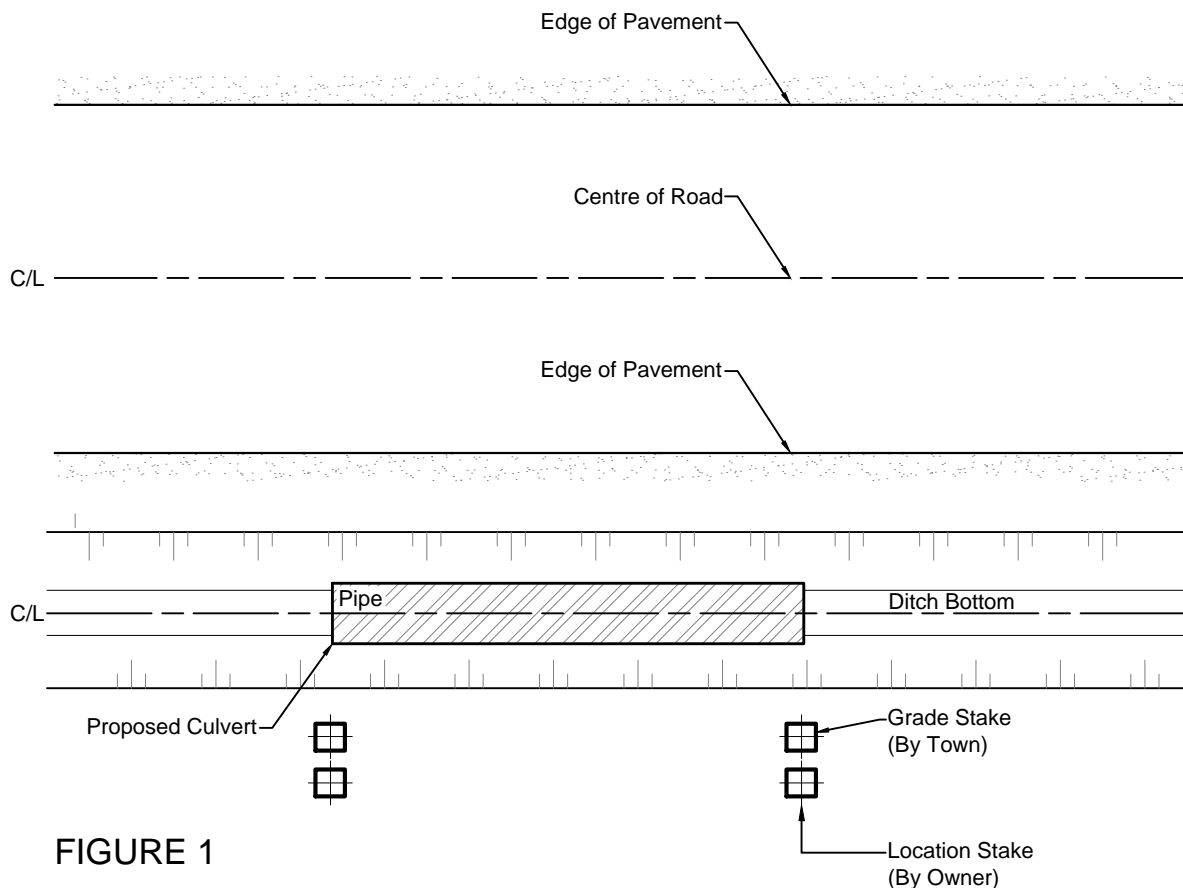

FIGURE 1

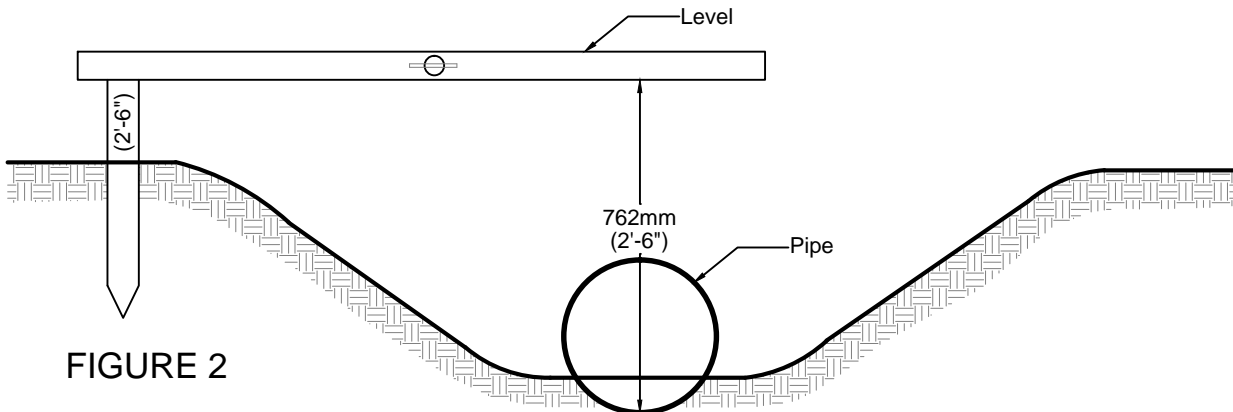



FIGURE 2

NOTES:

- 1 Clearly mark proposed driveway with location stakes (See Fig. 1)
- 2 Grade on grade stake is measured from top of stake to bottom of pipe (See Fig. 2)
- 3 Do not remove grade stakes until after final inspection.
- A All dimensions are in metres unless otherwise shown.

TOWN OF ESSEX
 Drainage Department
 Grade Stake Instructions



Date: August 7, 2013
 Drawn By: J.S.

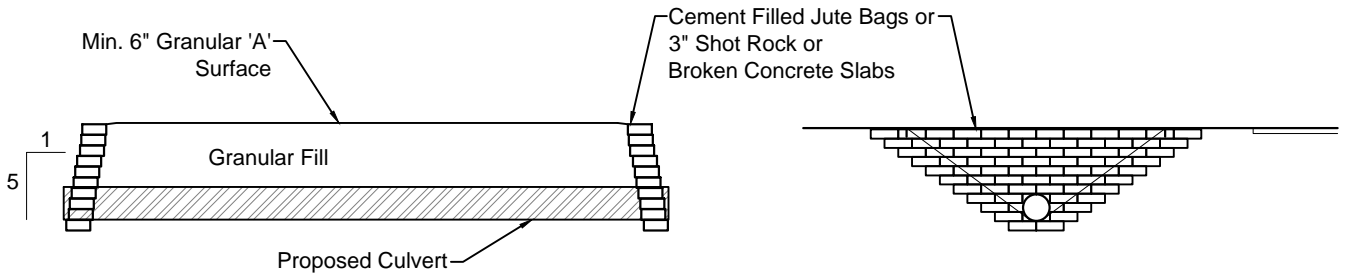

TYPE 'A'-FULL HEADWALL

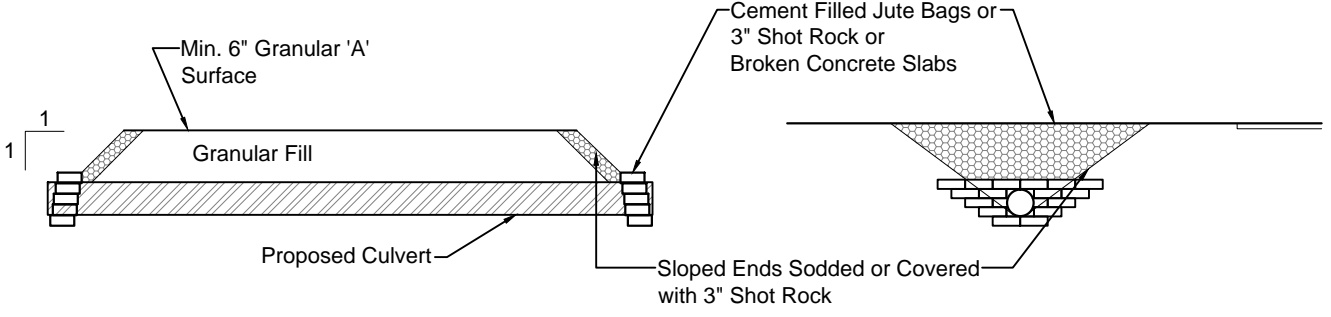

TYPE 'B'-PARTIAL HEADWALL

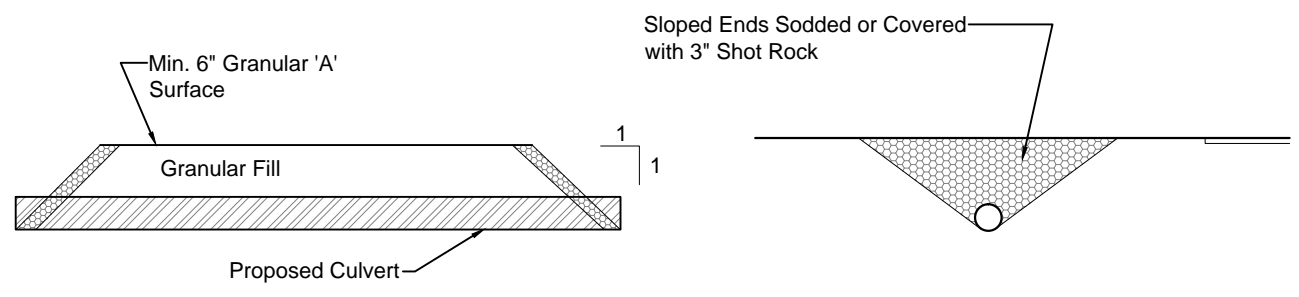

TYPE 'C'-NO HEADWALL

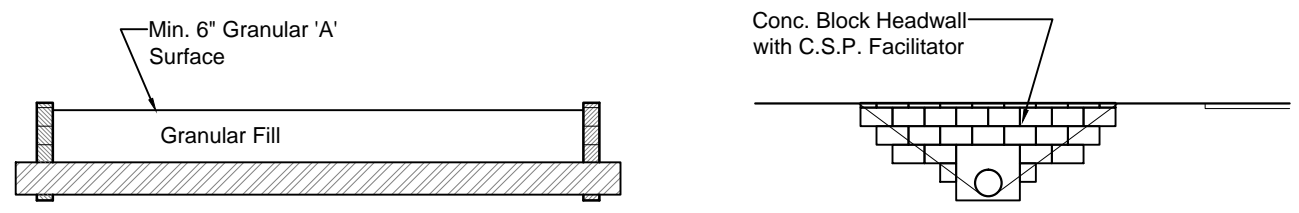

TYPE 'D'-BLOCK HEADWALL

TOWN OF ESSEX
 Drainage Department
 C.S.P. Culvert End Treatment



Date: August 8, 2013
 Drawn By: J.S.

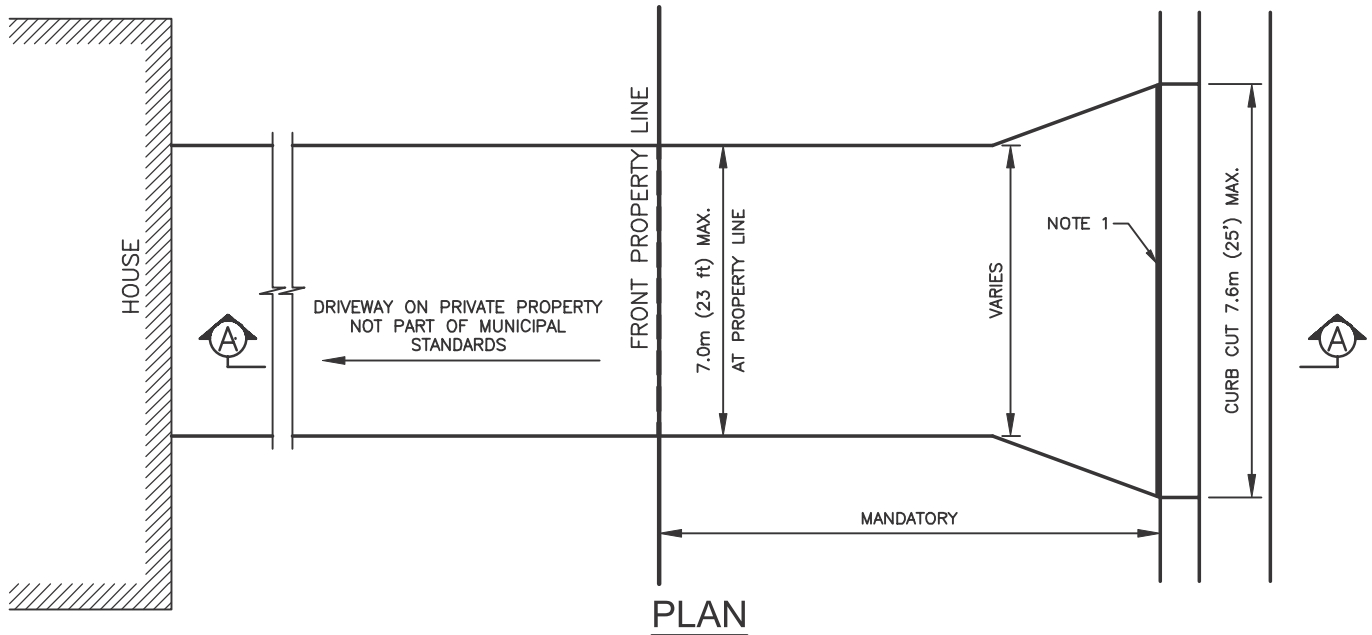

PLAN

ASPHALT SECTION A-A

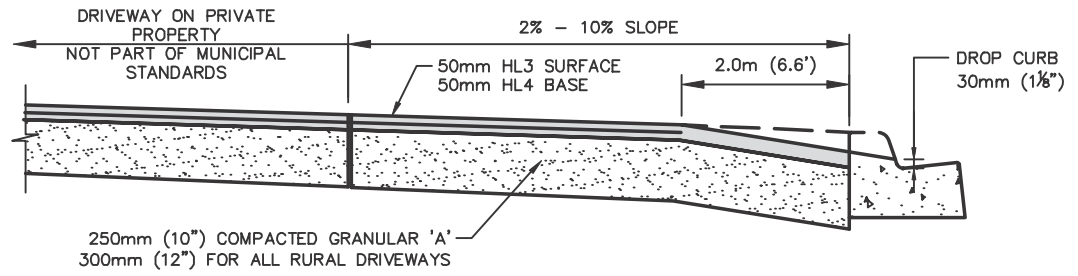

CONCRETE SECTION A-A

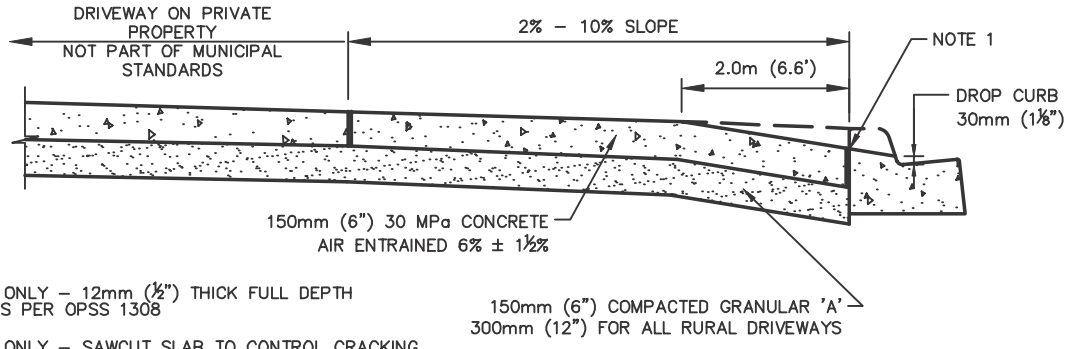

NOTES

1. FOR CONCRETE DRIVEWAYS ONLY – 12mm (½”) THICK FULL DEPTH PREMOLDED JOINT FILLER AS PER OPSS 1308
2. FOR CONCRETE DRIVEWAYS ONLY – SAWCUT SLAB TO CONTROL CRACKING.
3. ONLY ONE DRIVEWAY PER LOT IS PERMITTED.

FILENAME: C:\PW\WORKING DIRECTORY\PROJECTS 2020\33049\DWG\45610\203349-FG-CON CG DEC 14.DWG PLOTTED BY: PINSONNEAULT, LOUIS
 PLOT DATE: 2022-01-24 @ 11:15:22 AM PLOT SCALE: 1:1 PLOT STYLE: DILLON-STANDARD.CTB



No.	Revision Date
2	January 14, 2022
1	June 01, 2021

Town of Essex Development Manual

Figure D-1A

Residential Driveway Entrance Without Sidewalks